

SPECIFICATIONS

Size	Metric	British
Max. Working Height A	12.00m	39ft 4in
Max. Platform Height B	10.00m	32ft 10in
Overall Length(Without Outriggers)	3.19m	10ft 6in
Overall Length(With Outriggers) C	3.84m	12ft 7in
Overall Width D	1.76m	5ft 9in
Overall Height(Rails Up) E	2.59m	8ft 6in
Overall Height(Rails Down) F	1.82m	6ft
Platform Size(Length×Width)	2.88m×1.52m	9ft 5in × 5ft
Platform Extension Size G	1.43m	4ft 8in
Ground Clearance	0.24m	9in
Wheelbase H	2.29m	7ft 6in
Turning Radius(Inside/Outside)	2.15m/4.85m	7ft 1in/15ft 11in
Tyres	26×12-16.5	26×12-16.5

Performance		
S.W.L	454kg	1000lb
S.W.L On Extension	136kg	299lb
Max. Occupants (Indoor/Outdoor)	4/2	4/2
Gradeability	40%	40%
Travel Speed(Stowed)	5.00km/h	3.10mph
Travel Speed(Raised)	0.45km/h	0.28mph
Max. Working Slope	X-1.5°/Y-3°	X-1.5°/Y-3°
Up/Down Speed	38/46sec	38/46sec

Weight		
Overall Weight	4300kg	9479lb

Power		
Diesel Engine	18.2kW/3000rpm	18.2kW/3000rpm
Diesel Tank	47L	12.4gal
Hydraulic Tank	71L	18.7gal

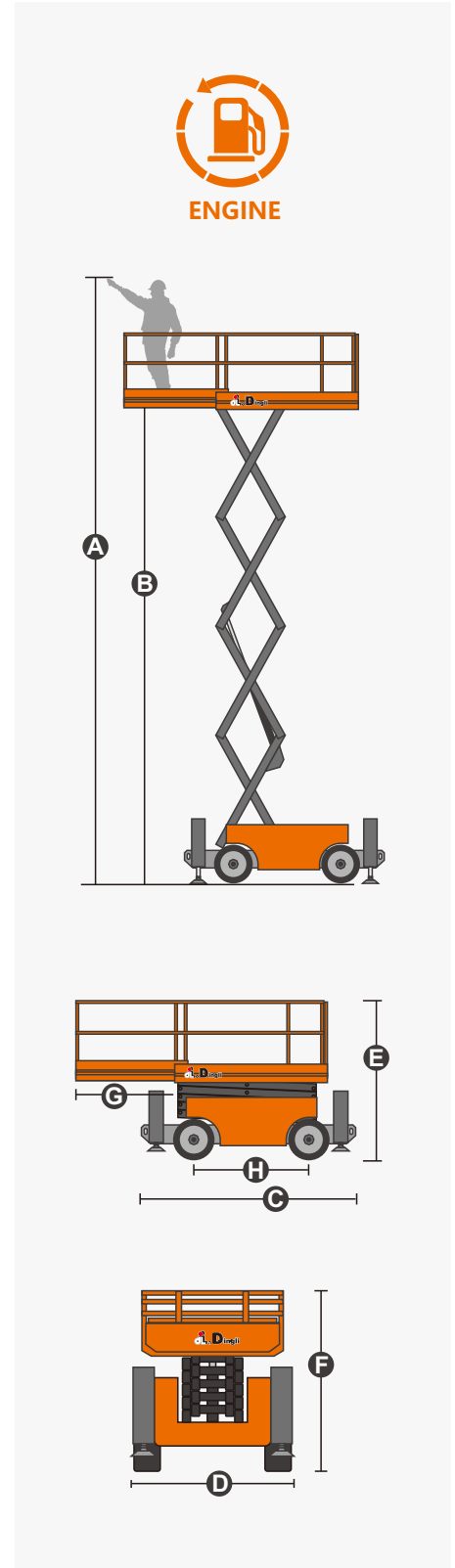

FEATURES

Standard Items

- Proportional Joystick Controls
- Self-Locking Gates
- One-Way Platform Extension Deck
- Four-Wheel Drive
- Two-Wheel Steering
- Automatic Braking System
- Self-Weight Lowering System
- Tubing Explosion-Proof System
- Onboard Fault Diagnostic System
- Tilt Alarm
- Motion Alarm
- Horn
- Hour Meter
- Hydraulic Oil Cooling System
- Flashing LED Beacon
- Foldable Guard Rails
- Drive Enable
- Manual Brake Release
- Lanyard Attachment Point
- Standard Transport Forklift Pockets
- Tie-Down And Lifting Points
- Automatic Leveling Hydraulic Outriggers
- Anti-Restart Engine Protection
- Emergency Stop Button
- Platform Load Sense System
- Drivable At Full Height
- Oscillating Axle Chassis



DINGLI AWP INDIA PRIVATE LIMITED

Address: Sahney Towers, 81, First Floor, Poonamallee High Road, Nerkundram,
Chennai, Tamil Nadu - 600 107
Telephone: +91-98846 48464
E-mail: support@dinglisaarc.com
Website: <https://dinglisaarc.com>

