

DINGLI

Exceed · New Height

Parts Manual

JCPT0607PA

From SN
JPPA023E00328-

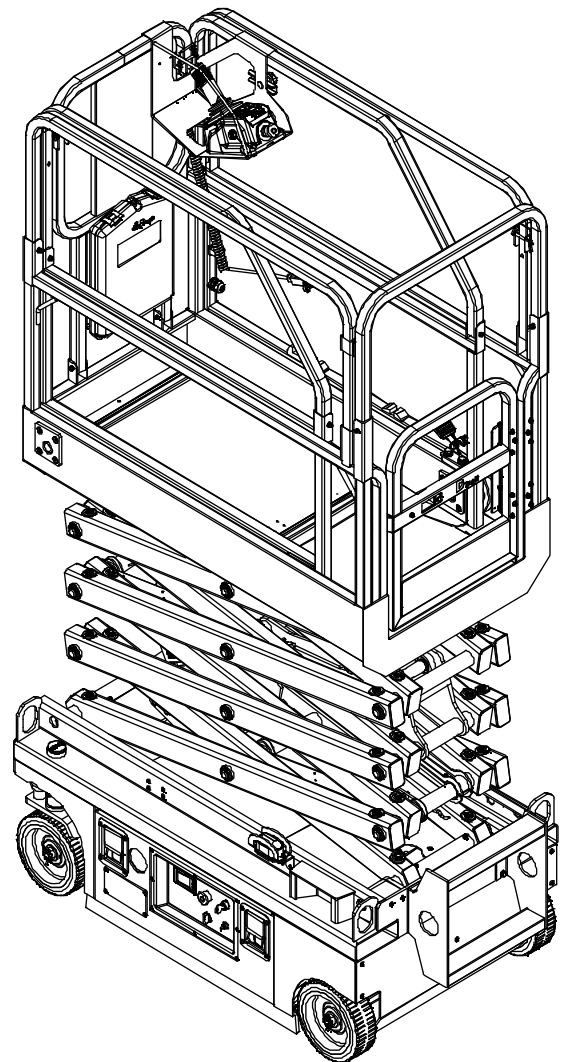

CE ANSI

Part Number: SM012120135

Version Number: Rev1.1

July 2023 Printing

DINGLI

Foreword

We are very appreciated for your interesting with Dingli machine and choosing it for your application. Our priority above all is you can use the machine safely for your application and you can benefit from the Dingli machine mostly. For these reason we hope you can:

1. Comply with employer, job site and local governmental rules.
2. Safeguard your commitment to quality by always using genuine Dingli spare parts. Remember, Dingli cannot accept responsibility for the failure of a separator equipped with non-original spare parts. We guarantee the quality and reliability of our products.
3. All sketch maps of parts shown in this manual are for reference only, it is the practical that counts. This manual includes all the latest information up to the date when it was printed. All responsibilities for the revision and explanation of the manual rest with the Dingli. We also preserve the right to edit the technology characteristic and content of the manual.
4. Anyone who read the manual or used the machine, is encouraged to notify Dingli Machinery Co, Ltd of any errors or send in suggestions for improvement. All communications will be carefully considered for future printings of this and other manuals, certainly if you have any question about the machine, please contact with our team by dialing technical support phone, sending email, or any methods you want, etc. Our contact information as bellow:

Please contact with:

DINGLI AWP INDIA PRIVATE LIMITED

Phone: +91-98846 48464

Email: support@dinglisaarc.com

Table of Contents

Section 1 Chassis

101.1	Steer Linkage and Wheels Assembly	2
102.1	Drive Wheel Assembly	5
103.1	Pothole Protection Assembly	7
104.1	Battery Pack Module	9
105.1	Motor Controller Assembly 2	11
106.1	Motor Controller Assembly 1	12
107.1	Ground Control Assembly	13
108.1	Ladder and Accessories.....	14

Section 2 Scissor

201.1	Scissor Assembly.....	18
202.1	Electric Cylinder Assembly	21

Section 3 Platform

301.1	Main Platform Assembly	24
302.1	Platform Extension Assembly	26
303.1	Platform Locking Device Assembly.....	28
304.1	Platform Control Assembly	29
305.1	Platform Control Box Assembly	30

Section 4 Electrical System

401.1	Electrical Harness	33
402.1	Power to Platform	35

Section 5 Decal

501.1	Decals with Words (CE).....	38
501.2	Decals with Words (ANSI).....	41
502.1	Decals with Symbols (CE).....	44
502.2	Decals with Symbols (ANSI)	47

Section 1 Chassis

101.1 Steer Linkage and Wheels Assembly

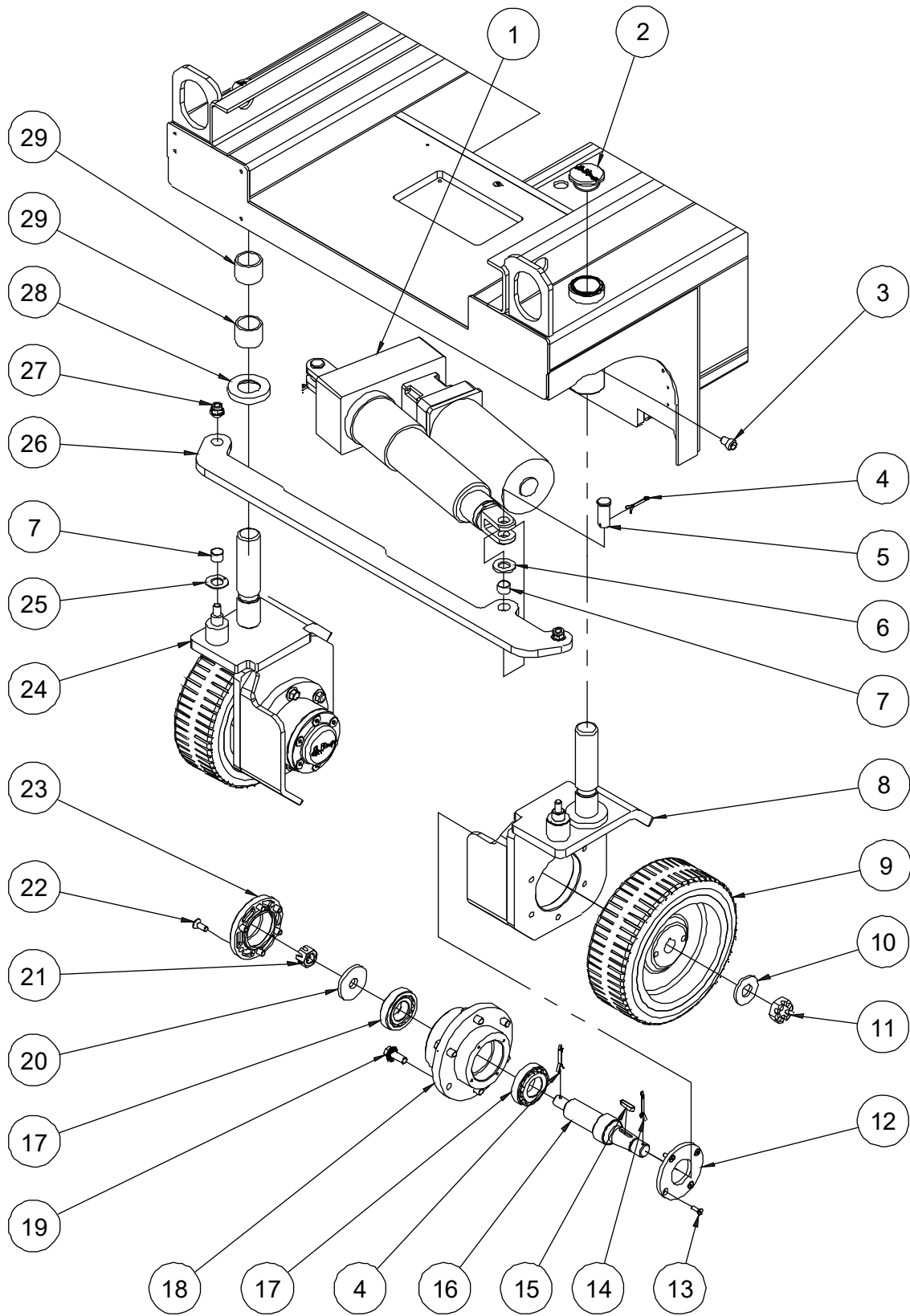

101.1 Steer Linkage and Wheels Assembly

Item	Part No.	Description	Qty.
1	10020558	Electric cylinder unit (EV)	1
--	10025141	Electric cylinder	1
--	10025142	Motor	1
2	10014561	Cover	2
3	10001073	Screw	2
4	00002405	Cotter pin GB/T 91 4×32	4
5	00000686	891-1634.5 Pin	2
6	10001074	Washer	2
7	00000351	8812-161812 Bearing	4
8	10020670	Steer yoke weldment	1
9	10020391	Wheel	2
10	10020495	Washer	2
11	10020494	Nut	2
12	10001502	Bearing cover	2
13	00000822	Screw GB/T 70.3 M5×16	8
14	00002480	Cotter pin GB/T 91 4×36	2
15	00006813	Key GB/T 1096 6×6×25	2
16	10013164	Wheel shaft	2
17	00001129	Bearing 30206 GB/T 297	4
18	10001503	Connection plate	2
19	00002887	Bolt QC/T 340 M10×25	12
20	10001104	Washer	2
21	00002077	Nut GB/T 9459 M16×1.5	2
22	00000765	Screw GB/T 70.3 M8×20	12
23	10000638	Cap	2
24	10020688	Steer yoke weldment	1
25	00000387	8832-18 Bearing	2
26	10020672	Tie rod	1
27	00002572	Nut GB/T 6183.1 M10	2

101.1 Steer Linkage and Wheels Assembly

Item	Part No.	Description	Qty.
28	10001504	Washer	2
29	00000414	8813-323830 Bearing	4

102.1 Drive Wheel Assembly

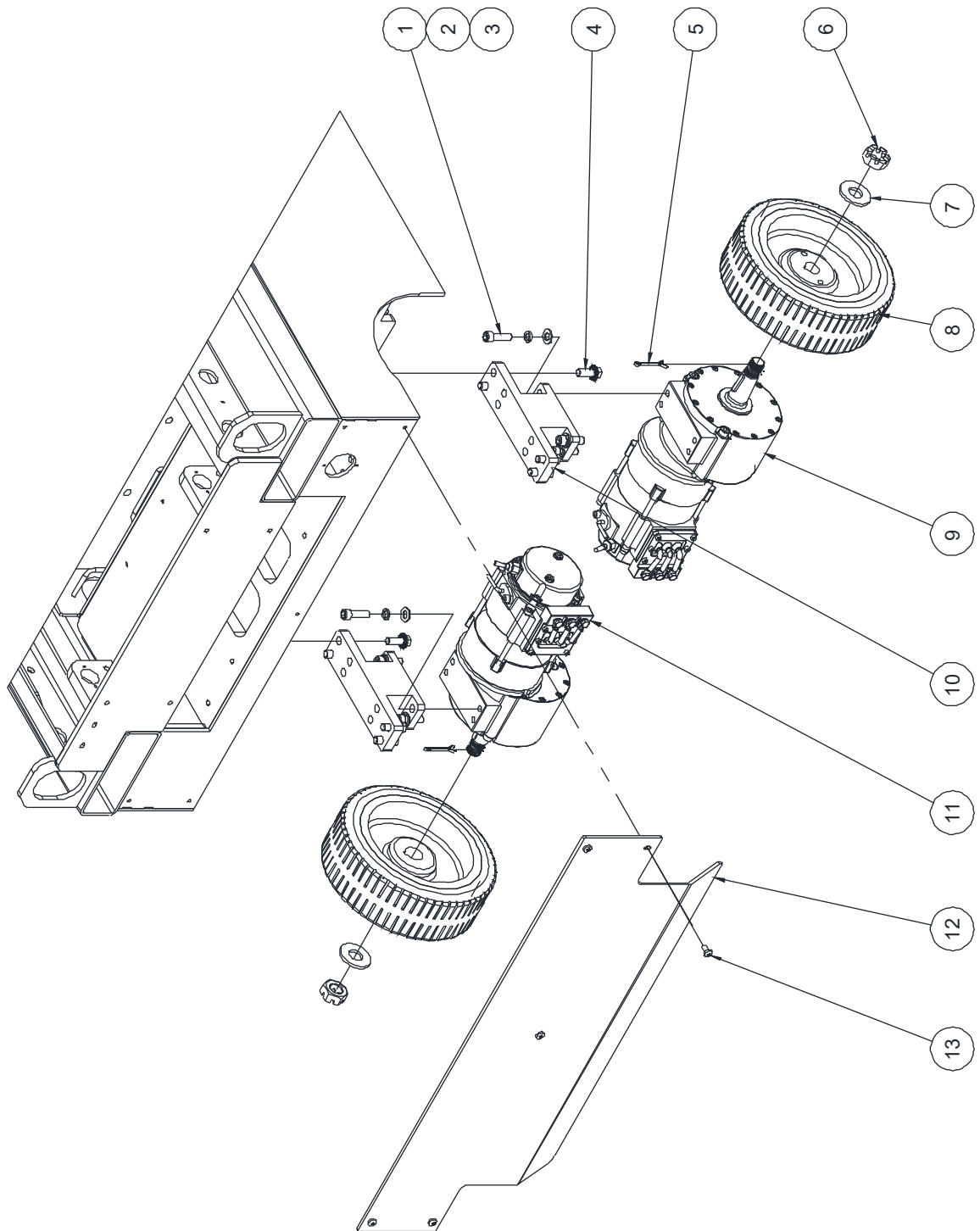

102.1 Drive Wheel Assembly

Item	Part No.	Description	Qty.
1	00001157	3/8-24×1 1/4" Screw ANSI B18.3	8
2	00000679	Washer GB/T 93 10	8
3	00000615	Washer GB/T 97.1 10	8
4	00002887	Bolt QC/T 340 M10×25	8
5	00002079	Cotter pin GB/T 91 4×40	2
6	10020494	Nut	2
7	10020495	Washer	2
8	10020391	Wheel	2
9	00010768	Right drive motor assembly	1
--	00010769	Right motor (with brake)	1
--	00009182	Reducer	1
--	00009704	Output shaft	1
--	00009183	Brake	1
--	00009469	Key GB/T 1096 6×6×32	1
10	10001534	Support	2
11	00010766	Left drive motor assembly	1
--	00010767	Left motor (with brake)	1
--	00009182	Reducer	1
--	00009704	Output shaft	1
--	00009183	Brake	1
--	00009469	Key GB/T 1096 6×6×32	1
12	10001562	Plate (without outlet hole)	1
	10002169	Plate (with one outlet hole)	1
	10016432	Plate (with two outlet hole)	1
13	00001060	Screw GB/T 818 M6×12 - H	5

103.1 Pothole Protection Assembly

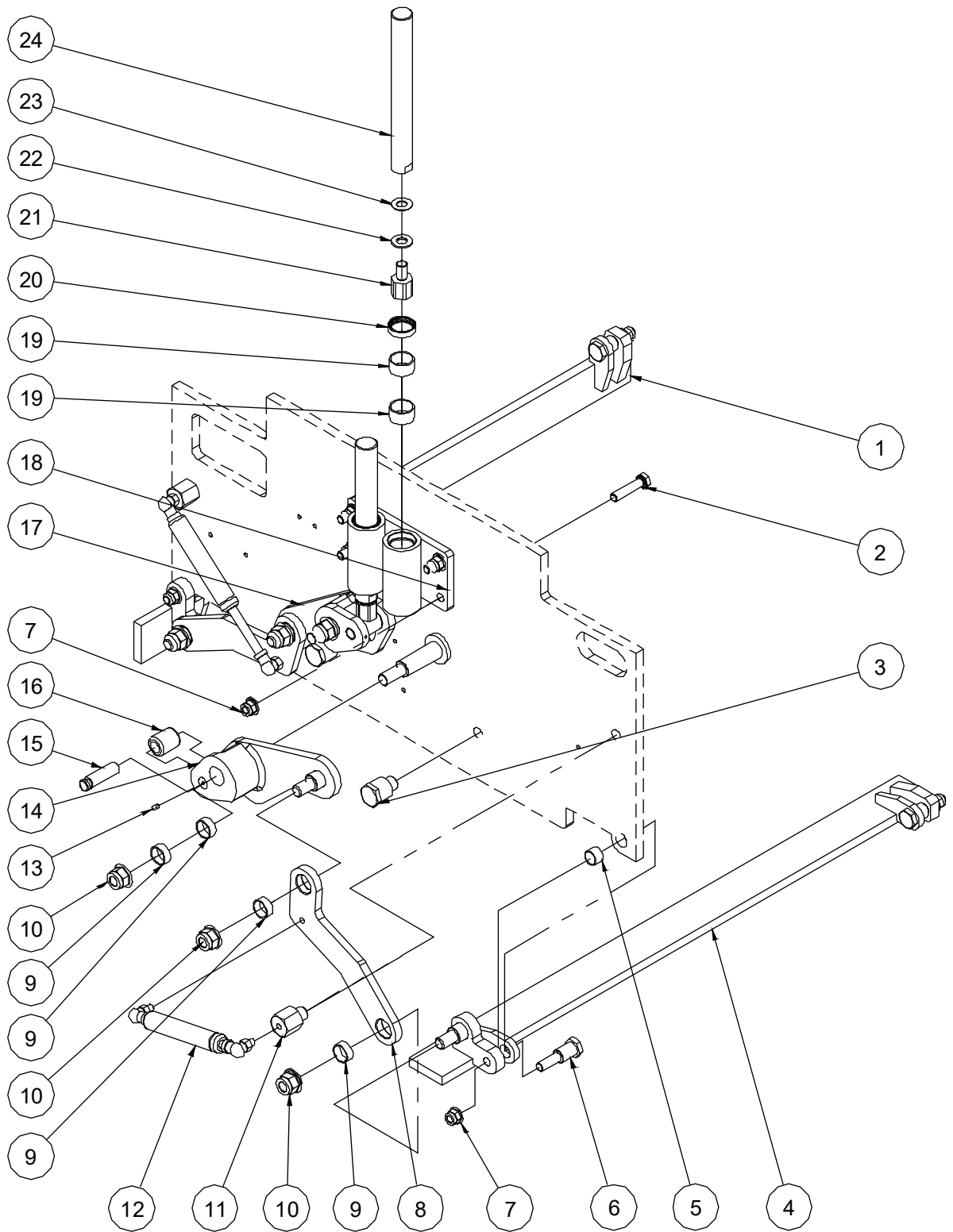

103.1 Pothole Protection Assembly

Item	Part No.	Description	Qty.
1	10022847	Pothole guard weldment	1
2	00002411	Bolt GB/T 5783 M10×45	4
3	10001466	Pin	2
4	10022846	Pothole guard weldment	1
5	00000351	8812-161812 Bearing	4
6	10001465	Pin	4
7	00002572	Nut GB/T 6183.1 M10	8
8	10001461	Pothole link plate	2
9	00000356	8812-202309 Bearing	8
10	00002577	Nut GB/T 6183.1 M14	6
11	10001464	Gas shock strut	2
12	10001495	Gas shock	2
13	00001039	Screw GB/T 78 M5×10	2
14	10001467	Linkage weldment	1
15	10001463	Pin	2
16	10001462	Roller	2
17	10001471	Linkage weldment	1
18	10014566	Pothole guide	1
19	00000367	8812-252815 Bearing	4
20	00007482	Seal GB/T 13871.1 FB 25 32 7 III	2
21	10001491	Pothole hole pusher pin	2
22	10001493	Adjusting washer 2	2
23	10001494	Adjusting washer 3	2
24	10001490	Pothole hole pusher rod	2

104.1 Battery Pack Module

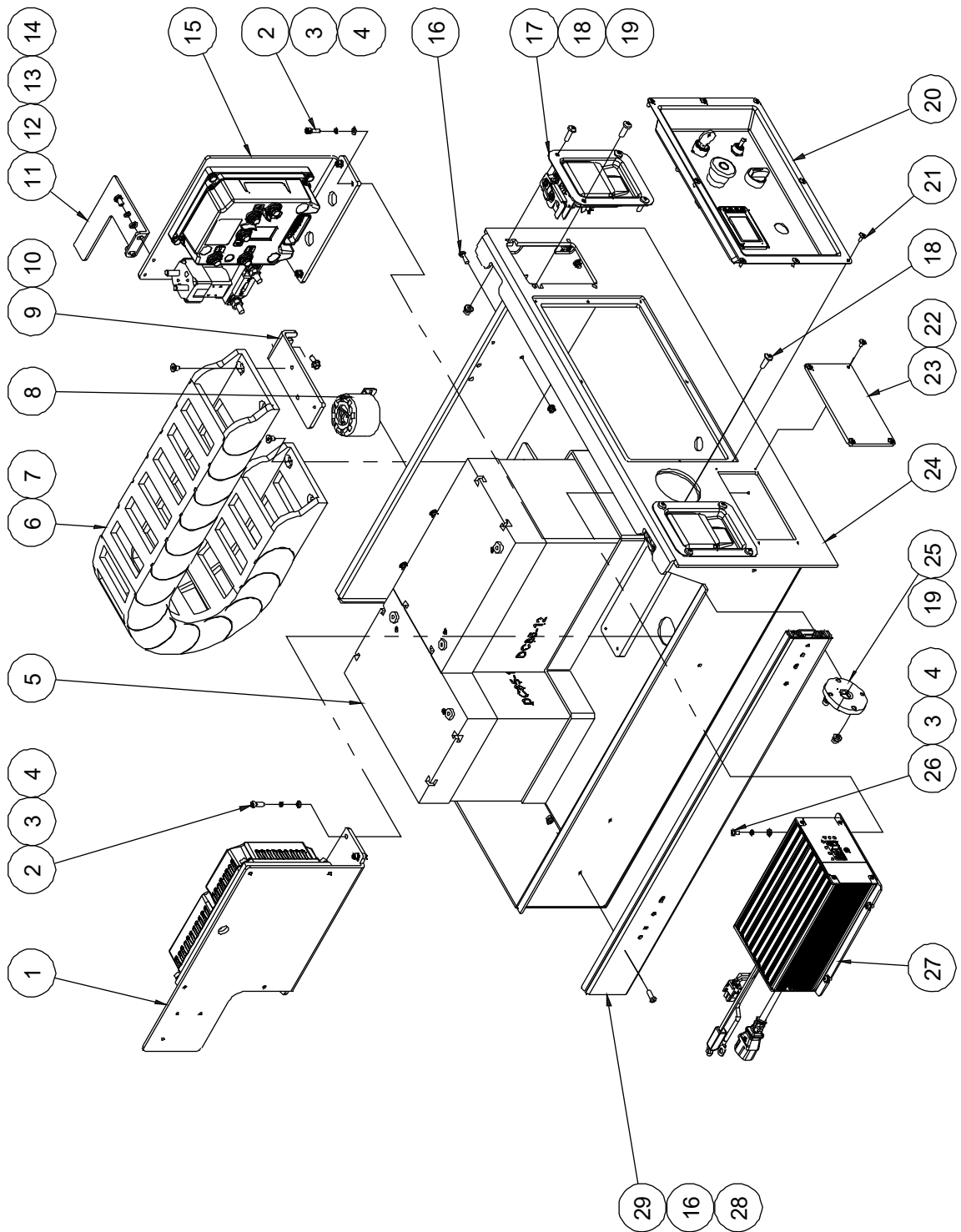

104.1 Battery Pack Module

Item	Part No.	Description	Qty.
1		Motor controller assembly 2 (refer to 105.1)	1
2	00001246	Screw GB/T 70.1 M5×16	8
3	00000606	Washer GB/T 93 5	12
4	00000605	Washer GB/T 97.1 5	12
5	00002350	Battery	2
6	10021809	Towline	1
7	00000828	Screw GB/T 70.3 M6×10	4
8	00001244	Alarm	1
9	10021810	Towline bracket	1
10	00002865	Bolt QC/T 340 M6×14	2
11	10018617	Press plate	1
12	00000745	Bolt GB/T 5783 M6×12	2
13	00000621	Washer GB/T 93 6	2
14	00000620	Washer GB/T 97.1 6	2
15		Motor controller assembly 1(refer to 106.1)	1
16	00001250	Screw GB/T 818 M5×16 - H	8
17	10011884	Latch	2
18	00001166	Screw GB/T 818 M6×20 - H	12
19	00002574	Nut GB/T 6183.1 M6	12
20		Ground control assembly (refer to 107.1)	1
21	00001002	Screw GB/T 973 M4×10	8
22	00001001	Screw GB/T 973 M4×8	4
23	10015566	Cover	1
24	10020676	Battery tray weldment	1
25	10000537	Half-round batten	2
26	00002391	Screw GB/T 818 M5×8 - H	4
27	00005060	Charger	1
28	00002573	Nut GB/T 6183.1 M5	8
29	10001541	Glide track	2

105.1 Motor Controller Assembly 2

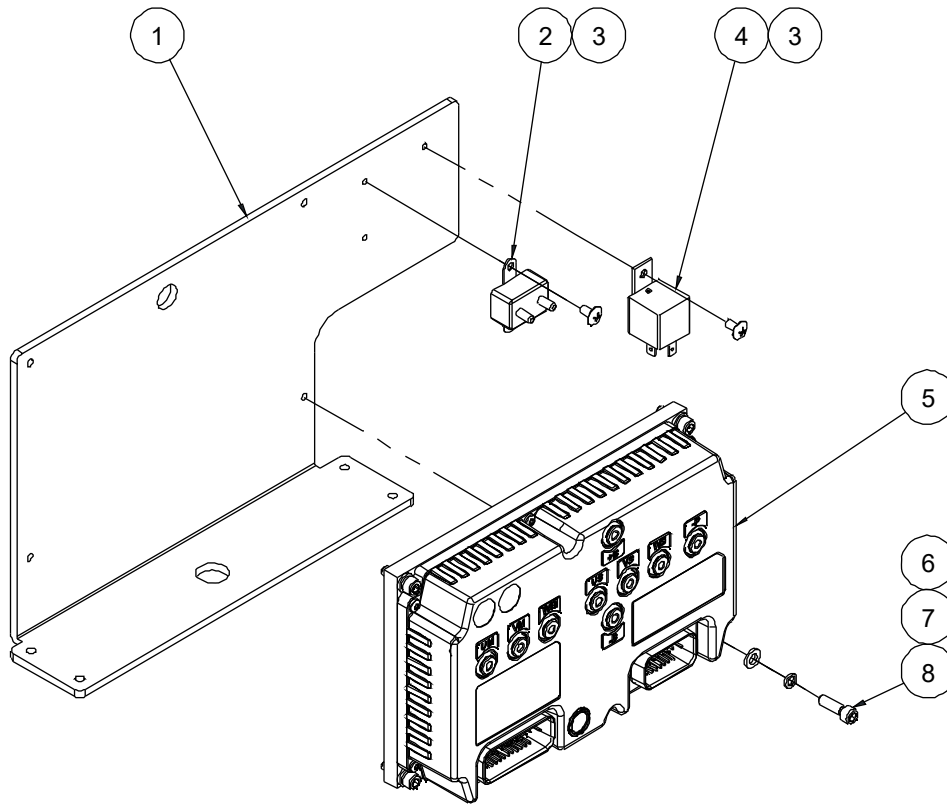

105.1 Motor Controller Assembly 2

Item	Part No.	Description	Qty.
1	10020692	Mounting plate 2	1
2	00007331	Circuit breaker	1
3	00000999	Screw GB/T 973 M5×10	3
4	00002561	Relay	1
5	00010222	Motor controller	1
6	00000620	Washer GB/T 97.1 6	4
7	00000621	Washer GB/T 93 6	4
8	00000774	Screw GB/T 70.1 M6×20	4

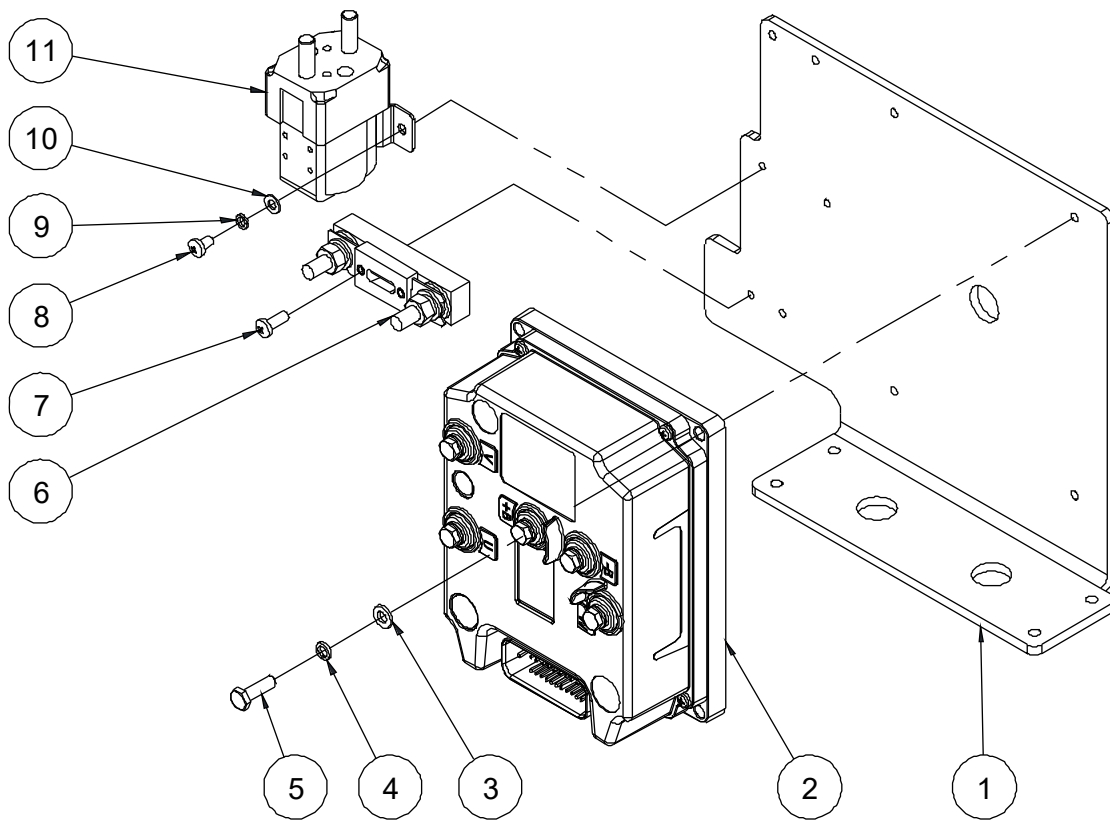
106.1 Motor Controller Assembly 1**106.1 Motor Controller Assembly 1**

Item	Part No.	Description	Qty.
1	10020679	Mounting plate 1	1
2	00010221	Motor controller	1
3	00000620	Washer GB/T 97.1 6	6
4	00000621	Washer GB/T 93 6	6
5	00000743	Screw GB/T 70.1 M6×20	4
6	00003069	200A Fuse assembly	1
--	00000759	200A Fuse	1
--	00000757	Fuse seat	1
7	00002313	Screw GB/T 818 M5×14 - H	2
8	00002391	Screw GB/T 818 M5×8 - H	2
9	00000606	Washer GB/T 93 5	2
10	00000605	Washer GB/T 97.1 5	2
11	00002028	DC Contactor	1

107.1 Ground Control Assembly

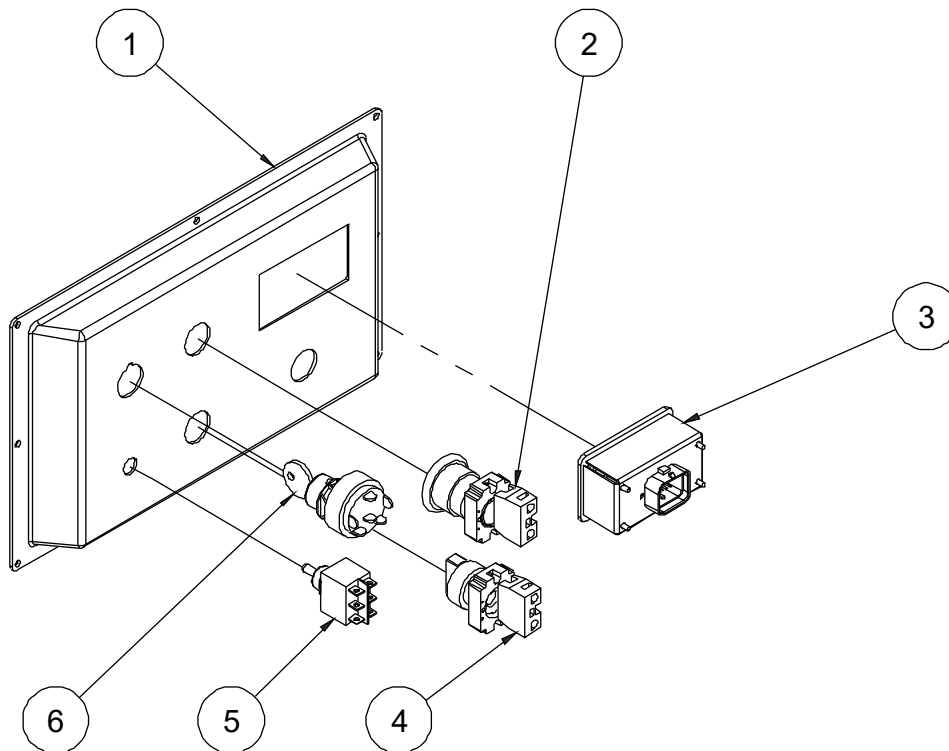

107.1 Ground Control Assembly

Item	Part No.	Description	Qty.
1	10020466	Ground control panel weldment	1
2	00000921	Emergency stop switch	1
--	00000754	Red mushroom head	1
--	00000752	Base with 1 NC contact	1
3	00008262	Display	1
4	00002565	Select switch	1
--	00002566	Select switch head	1
--	00002346	Base with 1 NO contact	1
5	00000738	Toggle switch	1
6	00001243	Key switch (key removable in off position)	1
	00003356	Key switch (key removable in all position)	1
--	00003050	Key	1

108.1 Ladder and Accessories

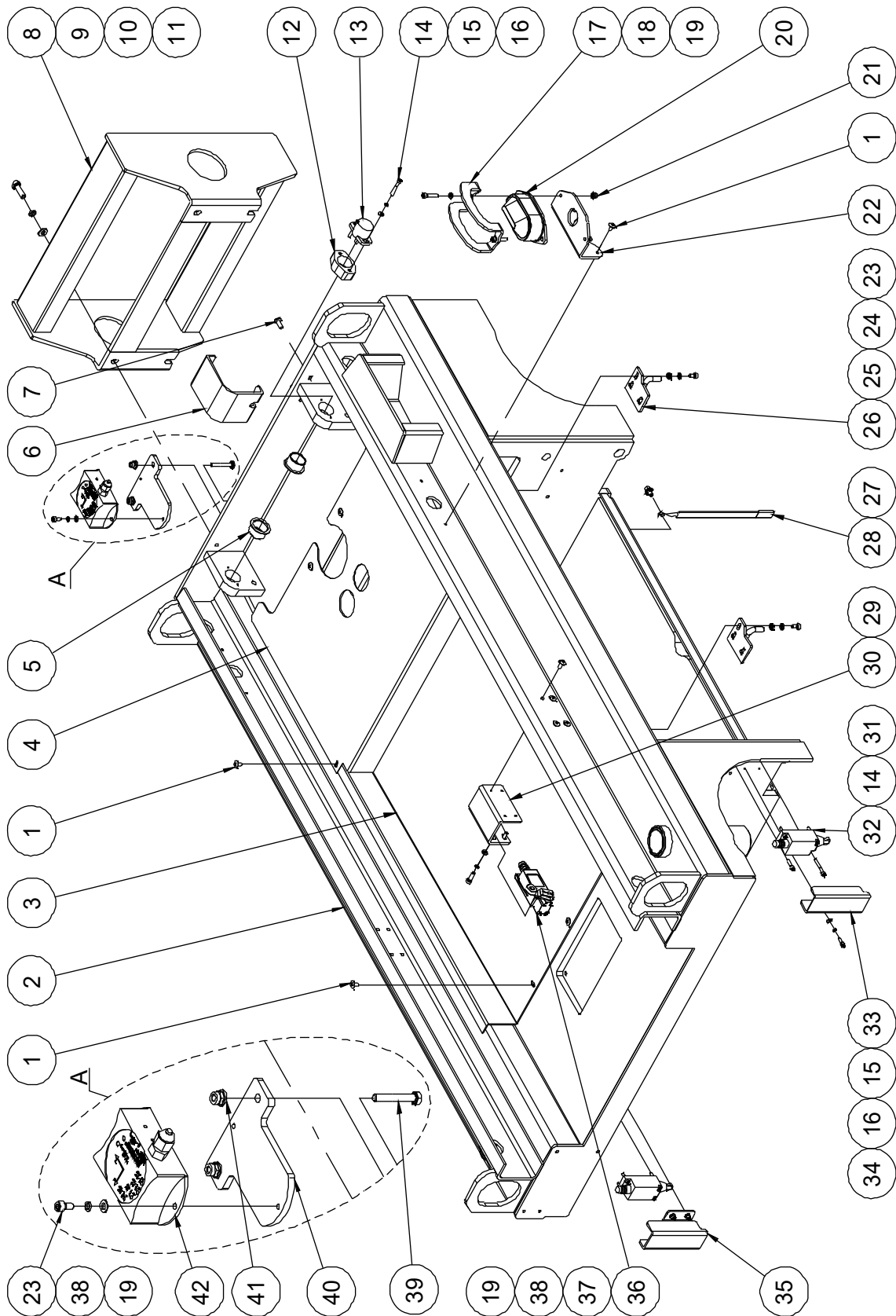

108.1 Ladder and Accessories

Item	Part No.	Description	Qty.
1	00000999	Screw GB/T 973 M5×10	9
2	10020682	Frame weldment	1
3	10001563	Cover	1
4	10001564	Cover	1
5	00000229	8822-25165 Bearing	2
6	10001570	Sensor cover	1
7	00002523	Screw GB/T 973 M5×16	2
8	10014896	Ladder (without circuit breaker bracket)	1
	10021406	Ladder (with circuit breaker bracket)	1
9	00000993	Bolt GB/T 5783 M8×25	4
10	00000609	Washer GB/T 93 8	4
11	00000608	Washer GB/T 97.1 8	4
12	10001569	Sensor bracket	1
13	00000644	Rotary sensor	1
14	00002415	Screw GB/T 70.1 M4×30	6
15	00000779	Washer GB/T 93 4	6
16	00000778	Washer GB/T 97.1 4	6
17	10000488	Beacon cover	1
18	00002484	Screw GB/T 70.1 M5×25	2
19	00000605	Washer GB/T 97.1 5	8
20	00000740	Beacon	1
21	00002573	Nut GB/T 6183.1 M5	2
22	10001565	Beacon bracket	1
23	00001030	Screw GB/T 70.1 M5×10	8
24	00007942	Washer GB/T 861.2 5	6
25	00007943	Washer GB/T 862.2 5	6
26	10011886	Lock clasp	2
27	00002863	Bolt QC/T 340 M6×10	1
28	10000487	Ground strap	1

108.1 Ladder and Accessories

Item	Part No.	Description	Qty.
29	00001011	Screw GB/T 973 M5×12	4
30	10022972	Switch bracket	1
31	00000604	Screw GB/T 70.1 M4×16	4
32	00002419	Limit switch	2
33	10001567	Switch cover	1
34	00001054	Screw GB/T 70.1 M4×12	4
35	10001566	Switch cover	1
36	00000748	Limit switch	1
37	00001246	Screw GB/T 70.1 M5×16	4
38	00000606	Washer GB/T 93 5	6
39	00003176	Bolt GB/T 5782 M6×40	2
40	10002025	Sensor bracket	1
41	00002574	Nut GB/T 6183.1 M6	2
42	00000694	Tilt sensor	1

Section 2 Scissor

201.1 Scissor Assembly

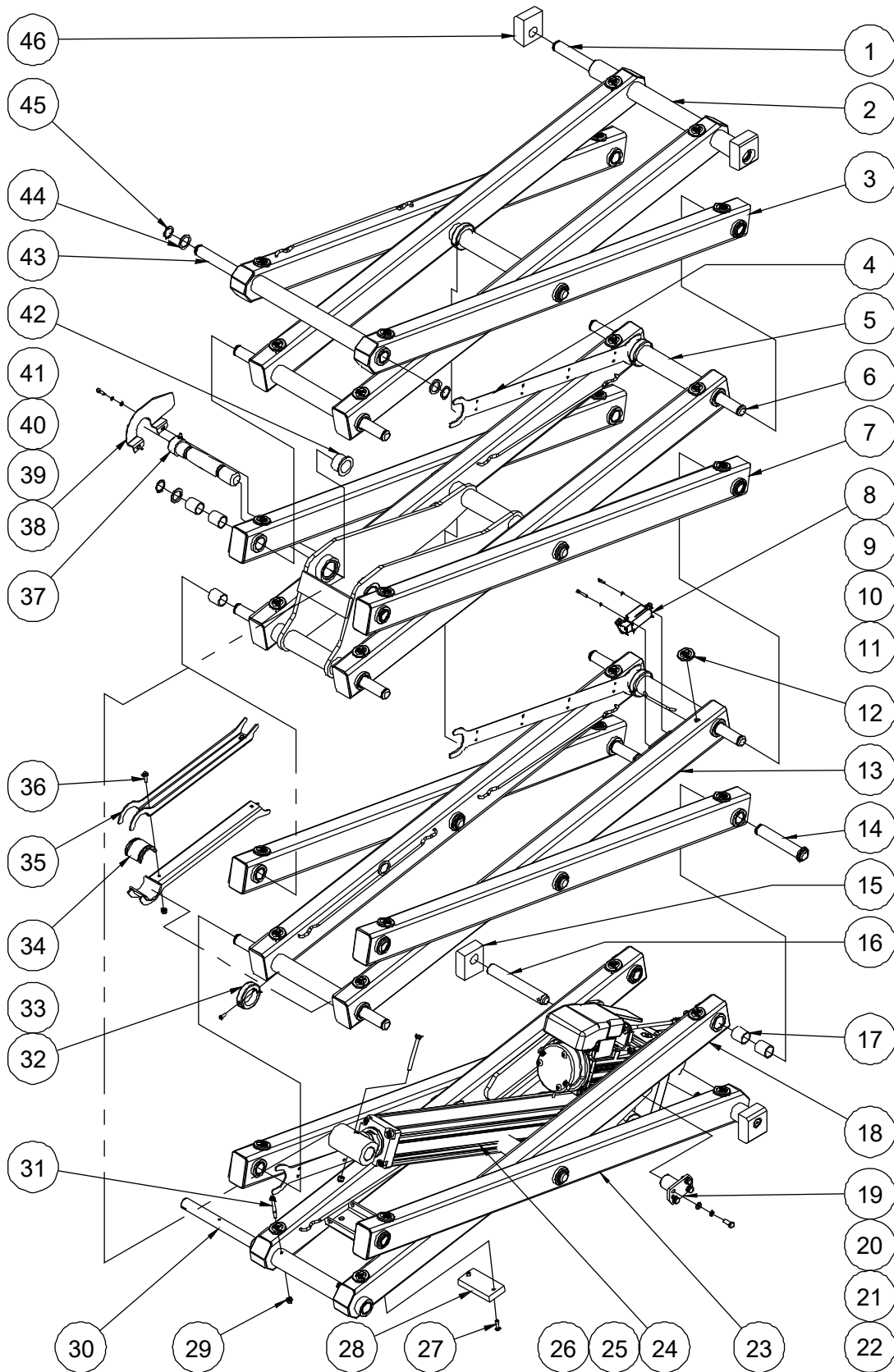

201.1 Scissor Assembly

Item	Part No.	Description	Qty.
1	00000561	899-25502 Pin	1
2	10027006	Inner arm 4	1
3	10027007	Outer arm 3	1
4	10001406	Cable bridge	3
5	10027005	Inner arm 3	1
6	00000560	899-25468 Pin	8
7	10027004	Outer arm 2	4
8	00000748	Limit switch	1
9	00001054	Screw GB/T 70.1 M4×12	2
10	00002228	Screw GB/T 70.1 M4×25	2
11	00000779	Washer GB/T 93 4	4
12	10000264	Block	32
13	10027003	Inner arm 2	1
14	00000559	899-25136 Pin	4
15	10001401	Chassis slider	2
16	00002334	896B-25×14 Pin	2
17	00011193	8813-253032 Bearing	72
18	10027002	Inner arm 1	1
19	10021818	Pin	2
20	00000608	Washer GB/T 97.1 8	8
21	00000609	Washer GB/T 93 8	8
22	00000875	Bolt GB/T 5783 M8×20	8
23	10027001	Outer arm 1	1
24		Electric cylinder assembly (refer to 202.1)	1
25	00001163	Nut GB/T 6182 M8	1
26	00001026	Bolt GB/T 5782 M8×80	1
27	00000832	Screw GB/T 70.3 M6×25	2
28	10001400	Pothole pusher	1
29	00002574	Nut GB/T 6183.1 M6	6

201.1 Scissor Assembly

Item	Part No.	Description	Qty.
30	10001405	Pin	1
31	00002569	Bolt GB/T 16674 M6×55	4
32	10011776	Collar	5
33	00000822	Screw GB/T 70.3 M5×16	4
34	10001403	Safety arm bushing	2
35	10001402	Safety arm	2
36	00002866	Bolt QC/T 340 M6×20	2
37	10026991	Pin	1
38	10022883	Harness cover	1
39	00001246	Screw GB/T 70.1 M5×16	2
40	00000606	Washer GB/T 93 5	2
41	00000605	Washer GB/T 97.1 5	2
42	00011194	8823-3227 Bearing	2
43	00000562	899-25516Pin	1
44	10001404	Washer	28
45	00000781	Washer JB/ZQ 4342-25	28
46	10001420	Platform slider	2

202.1 Electric Cylinder Assembly

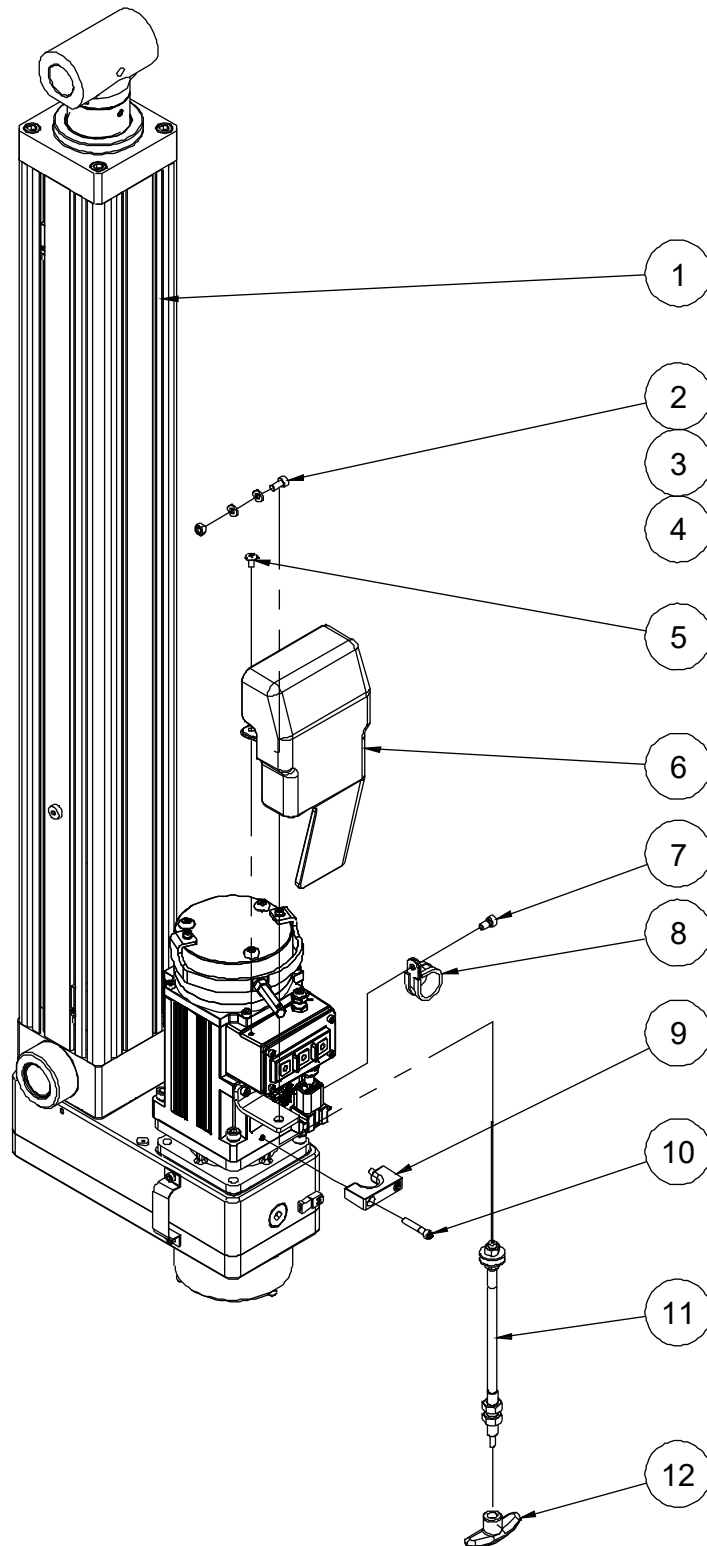

202.1 Electric Cylinder Assembly

Item	Part No.	Description	Qty.
1	10027723	Electric cylinder unit (HL)	1
--	00011642	Electric cylinder	1
--	00010680	Reducer	1
--	00010677	Motor	1
2	10001457	Screw	1
3	00000620	Washer GB/T 97.1 6	2
4	00002247	Nut GB/T 6170 M6	1
5	00000999	Screw GB/T 973 M5×10	3
6	10023689	Motor cover	1
7	00002029	Screw GB/T 70.1 M6×12	1
8	10023676	Clamp	1
9	10017978	Clamp	1
10	00001253	Screw GB/T 70.1 M5×30	2
11	10022949	Emergency down cable assembly	1
12	10000410	Lowering knob JB/T 7274.6 BM5×70	1

Section 3 Platform

301.1 Main Platform Assembly

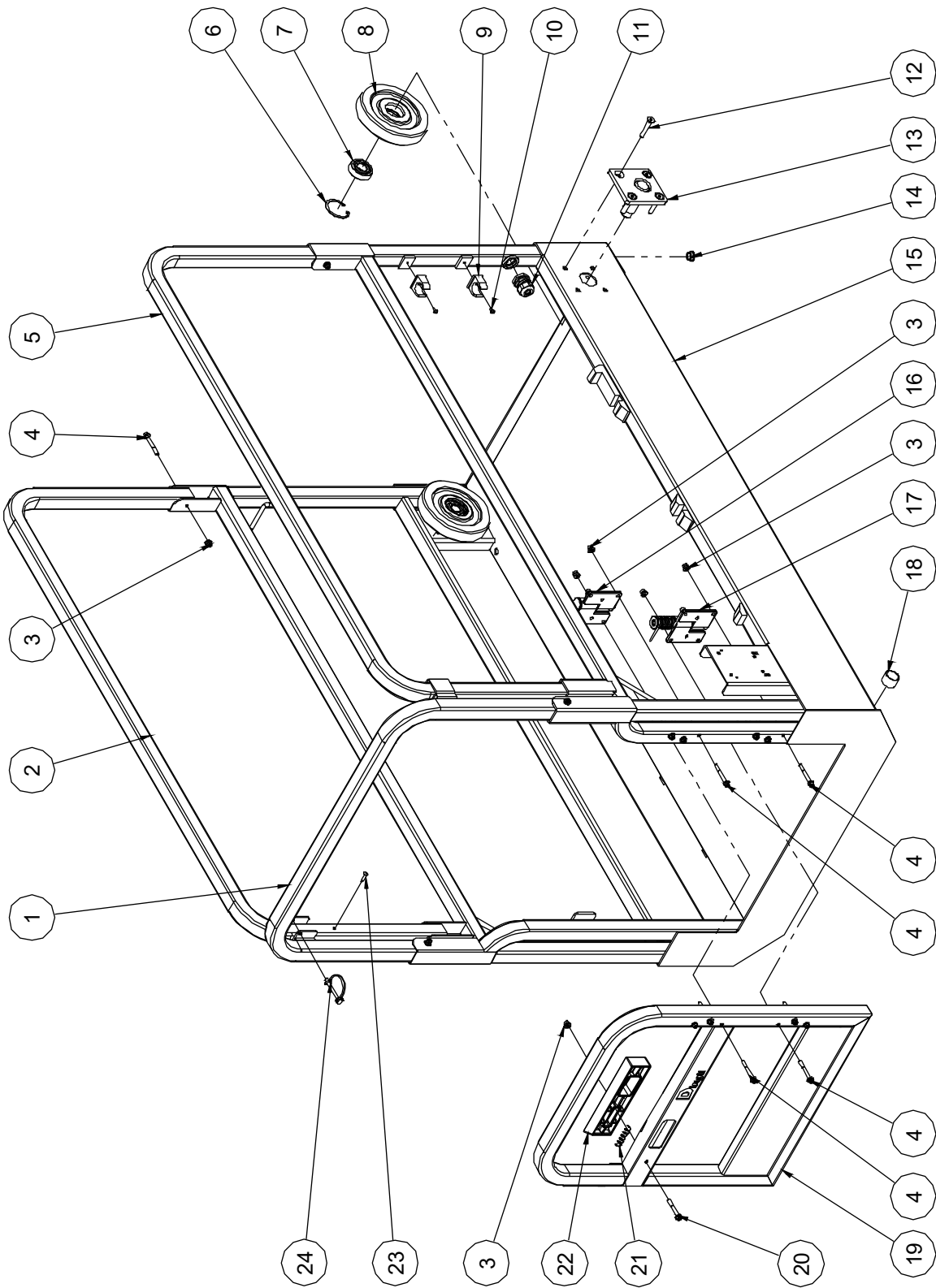

301.1 Main Platform Assembly

Item	Part No.	Description	Qty.
1	10001278	Rear rail	1
2	10001238	Upper main rail, left	1
3	00002574	Nut GB/T 6183.1 M6	19
4	00002581	Bolt GB/T 16674 M6×50	18
5	10001417	Upper main rail, right	1
6	00000887	Circlips GB/T 893.1-47	2
7	00001295	Bearing GB/T 276-1994 - 6204	2
8	10002031	Roller	2
9	00001823	Clip 24	2
10	00004385	Screw GB/T 823 M4×8	2
11	00002316	Water-proof joint M24	1
12	00001154	Screw GB/T 70.3 M8×45	8
13	10000307	Roller bracket	2
14	10001389	Sheath	1
15	10002009	Main deck weldment	1
16	10000299	Hinge A	1
17	10000302	Hinge B	1
18	00000368	8812-252820 Bearing	2
19	10001250	Entry gate	1
20	00002585	Bolt GB/T 16674 M6×45	1
21	10002379	Spring	1
22	10001255	Latch handle	1
23	00001991	Rivet GB/T 12618.4 4.8×16	2
24	10001178	Inserted pin	2

302.1 Platform Extension Assembly

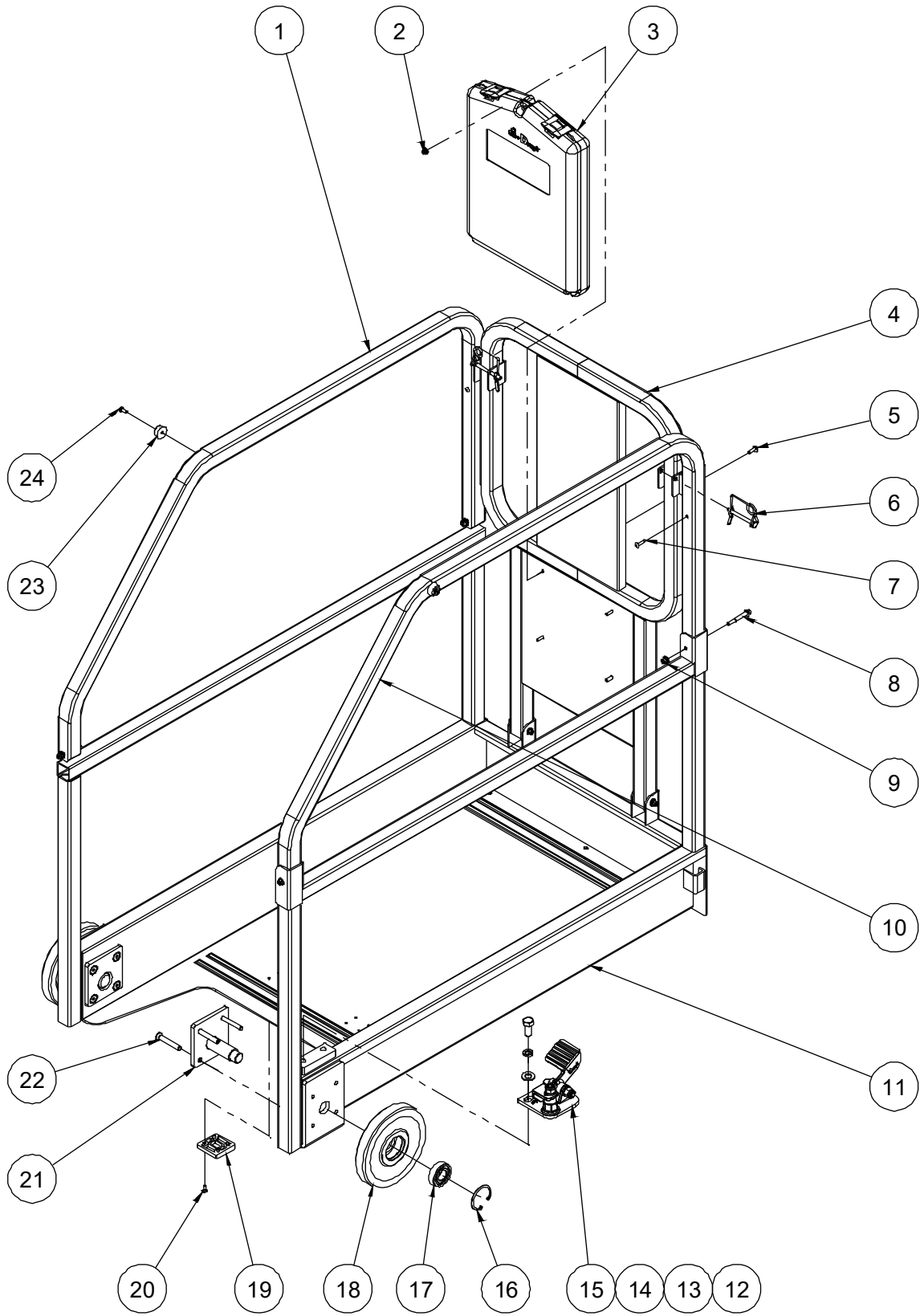

302.1 Platform Extension Assembly

Item	Part No.	Description	Qty.
1	10001245	Upper extension rail, left	1
2	00002573	Nut GB/T 6183.1 M5	4
3	50000555	Manual box	1
4	10001266	Front rail	1
5	00002523	Screw GB/T 973 M5×16	4
6	10001178	Inserted pin	2
7	00001991	Rivet GB/T 12618.4 4.8×16	2
8	00002581	Bolt GB/T 16674 M6×50	6
9	00002574	Nut GB/T 6183.1 M6	6
10	10001247	Upper extension rail, right	1
11	10012846	Extension deck weldment	1
12	00000816	Bolt GB/T 5783 M12×25	2
13	00000815	Washer GB/T 93 12	2
14	00000814	Washer GB/T 97.1 12	2
15	10012174	Platform locking device assembly (refer to 303.1)	1
16	00000887	Circlips GB/T 893.1-47	2
17	00001295	Bearing GB/T 276-1994 - 6204	2
18	10002054	Roller	2
19	10000046	Slide pad	2
20	00002337	Screw GB/T 819 M5×12 - H	8
21	10000307	Roller bracket	2
22	00001155	Screw GB/T 70.3 M8×55	8
23	10000376	Bumper	2
24	00000607	Screw GB/T 818 M5×12 - H	2

303.1 Platform Locking Device Assembly

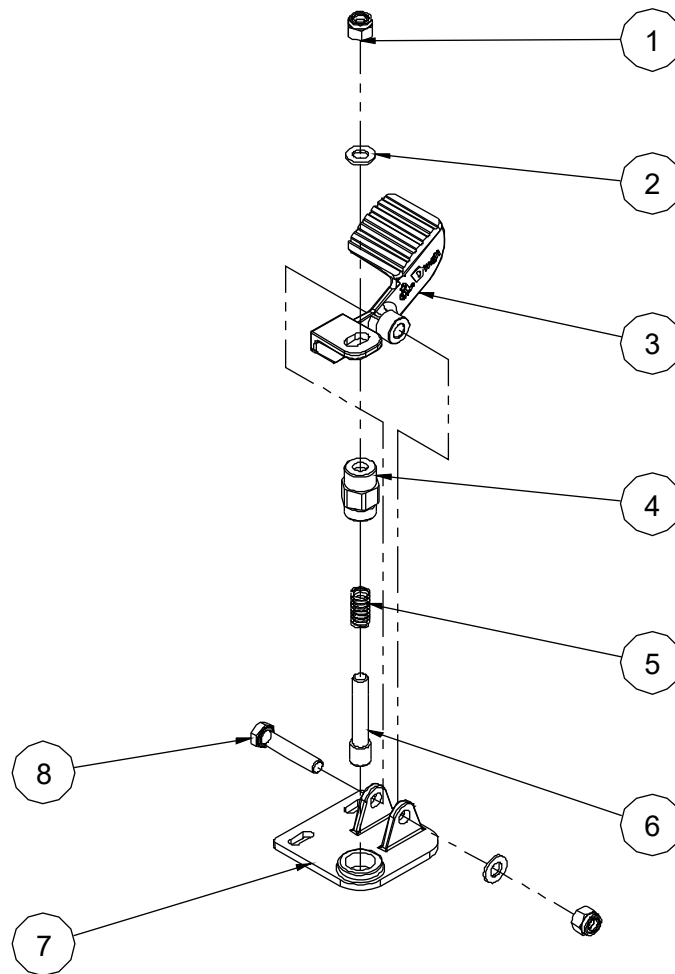

303.1 Platform Locking Device Assembly

Item	Part No.	Description	Qty.
1	00000623	Nut GB/T 6182 M10	2
2	00000615	Washer GB/T 97.1 10	2
3	10000334	Foot pedal	1
4	10000337	Lock pin housing	1
5	10000336	Spring	1
6	10000338	Lock pin	1
7	10012175	Bracket	1
8	00002030	Bolt GB/T 5782 M10×50	1

304.1 Platform Control Assembly

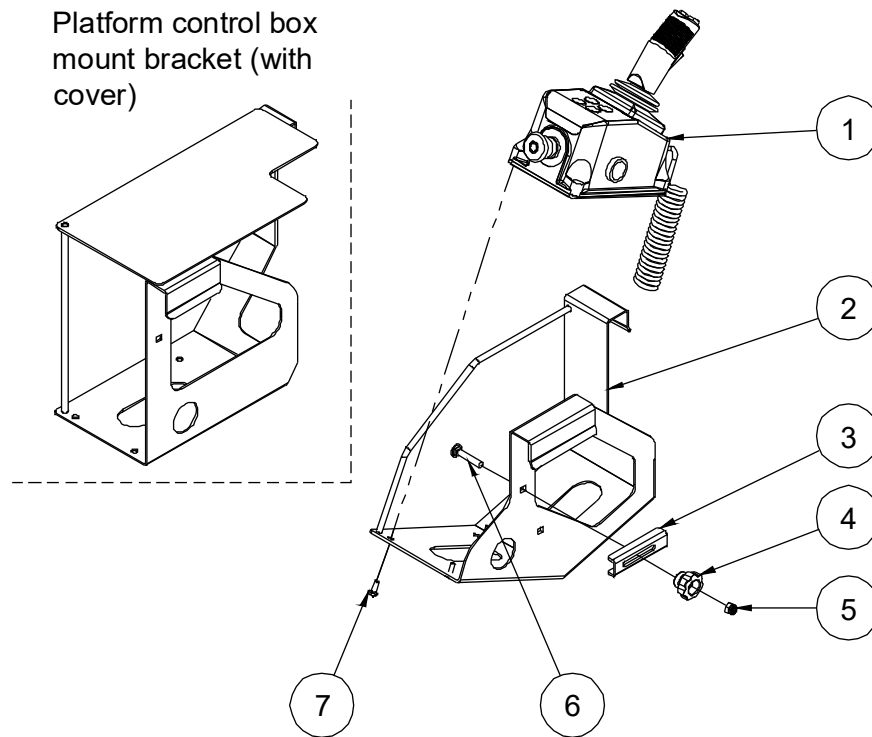

304.1 Platform Control Assembly

Item	Part No.	Description	Qty.
1	00007739	Platform control box assembly (refer to 305.1)	1
2	10001251	Platform control box mount bracket	1
	10001949	Platform control box mount bracket (with cover)	1
3	10002023	Locating plate	1
4	10004827	Handle	1
5	00001163	Nut GB/T 6182 M8	1
6	00004384	Bolt GB/T 801 M8×45	1
7	00001986	Screw GB/T 818 M6×16 - H	4

305.1 Platform Control Box Assembly

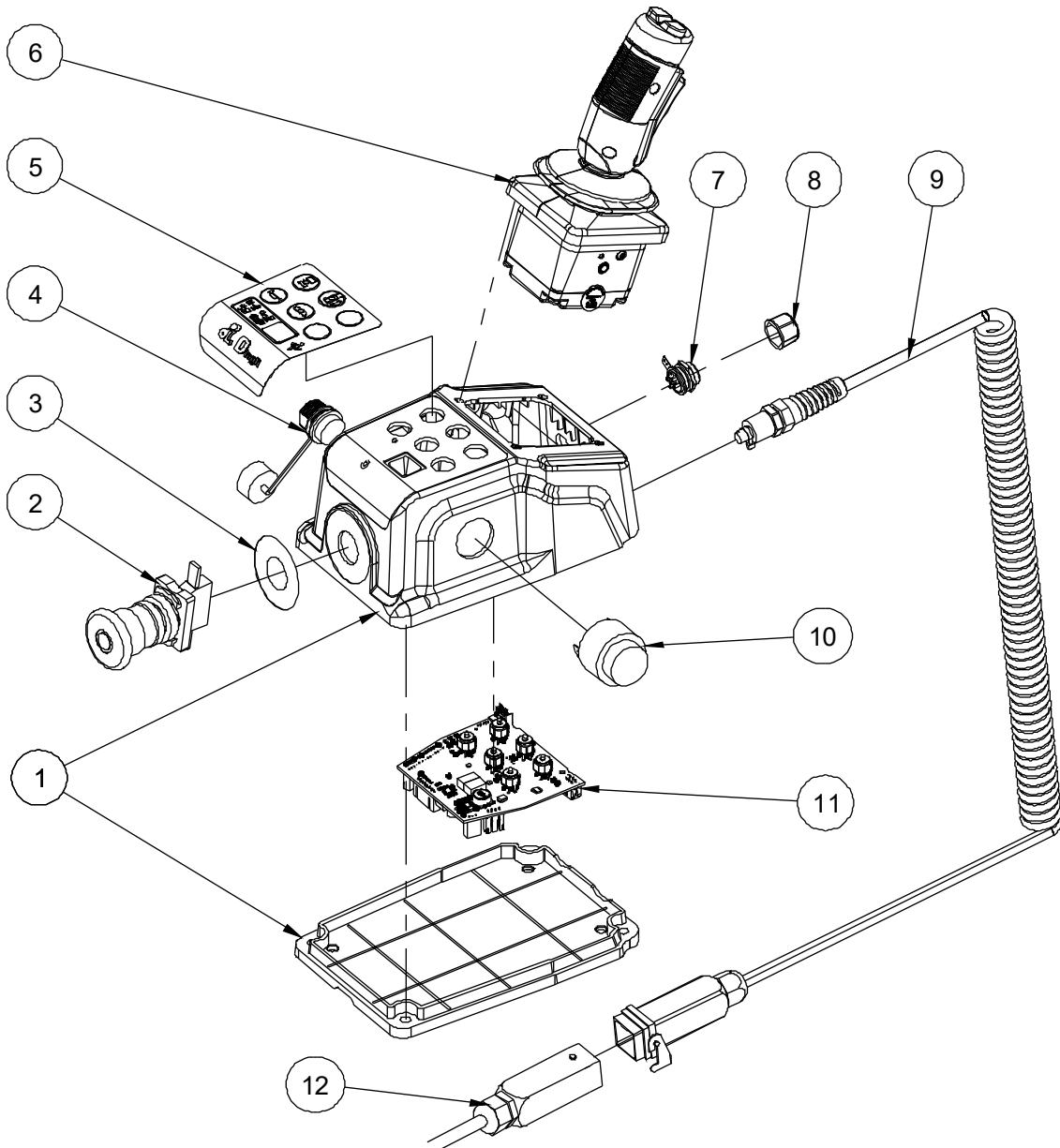

305.1 Platform Control Box Assembly

Item	Part No.	Description	Qty.
1	00008649	Shell components	1
2	00000713	Emergency stop switch	1
--	00003045	Red mushroom head	1
--	00003046	Base with 1 NO contact	1
3	00002328	Decal, Emergency stop panel	1
4	00008650	USB Cable	1
5	00008646	Decal, Platform control panel	1
6	00009010	Joystick	1
--	00003033	Function enable switch	1
--	00009012	Joystick cover	1
--	00003035	Joystick steer switch	1
--	00003036	Switch boot	1
7	00008651	Connector	1
8	00008652	Connector Cap	1
9	00008647	Coil cord	1
--	00007855	Hood	1
--	00007856	Female insert	1
--	00007857	Female contacts	5
--	00003043	Cable gland	1
10	00000712	Alarm	1
11	00008648	PCU Main board	1
12	00009221	Platform control box harness	1
--	00008172	Housing	1
--	00008174	Male insert	1
--	00008642	Male contacts	5
--	00003043	Cable gland	1

Section 4 Electrical System

401.1 Electrical Harness

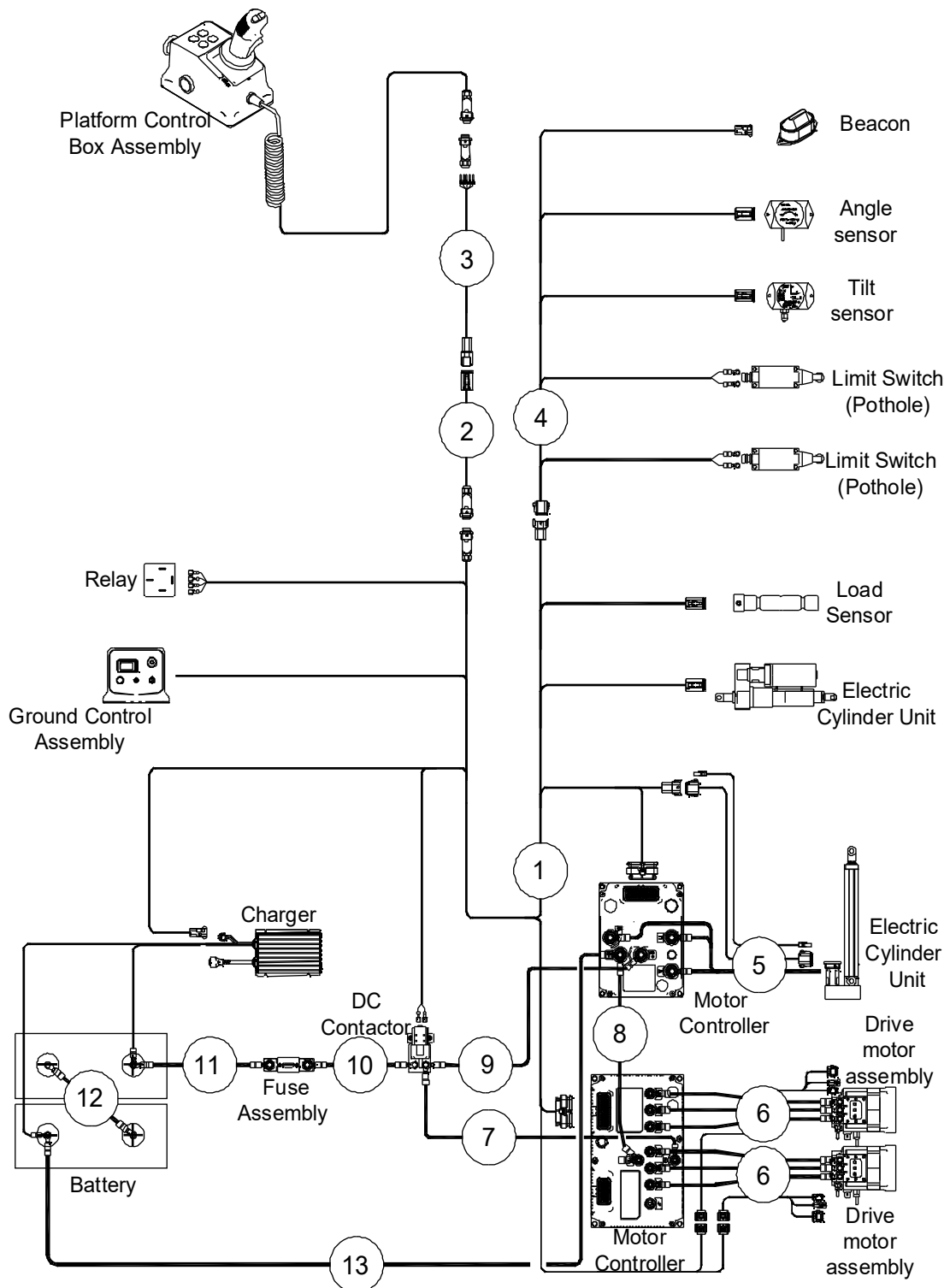

401.1 Electrical Harness

Item	Part No.	Description	Qty.
1	00009218	ECU harness	1
2	00009219	Drag chain harness	1
3	00009221	Platform control box harness	1
4	00009532	Sensor and Limit harness	1
5	00009223	Lift motor harness	1
6	00009752	Drive motor harness	2
7	00009228	Drive motor controller positive harness	1
8	00009231	Drive motor controller negative harness	1
9	00009227	Lift motor controller positive harness	1
10	00009226	Contactorm harness	1
11	00009225	Fuse harness	1
12	00002660	Battery harness	1
13	00009230	Lift motor controller negative harness	1

402.1 Power to Platform

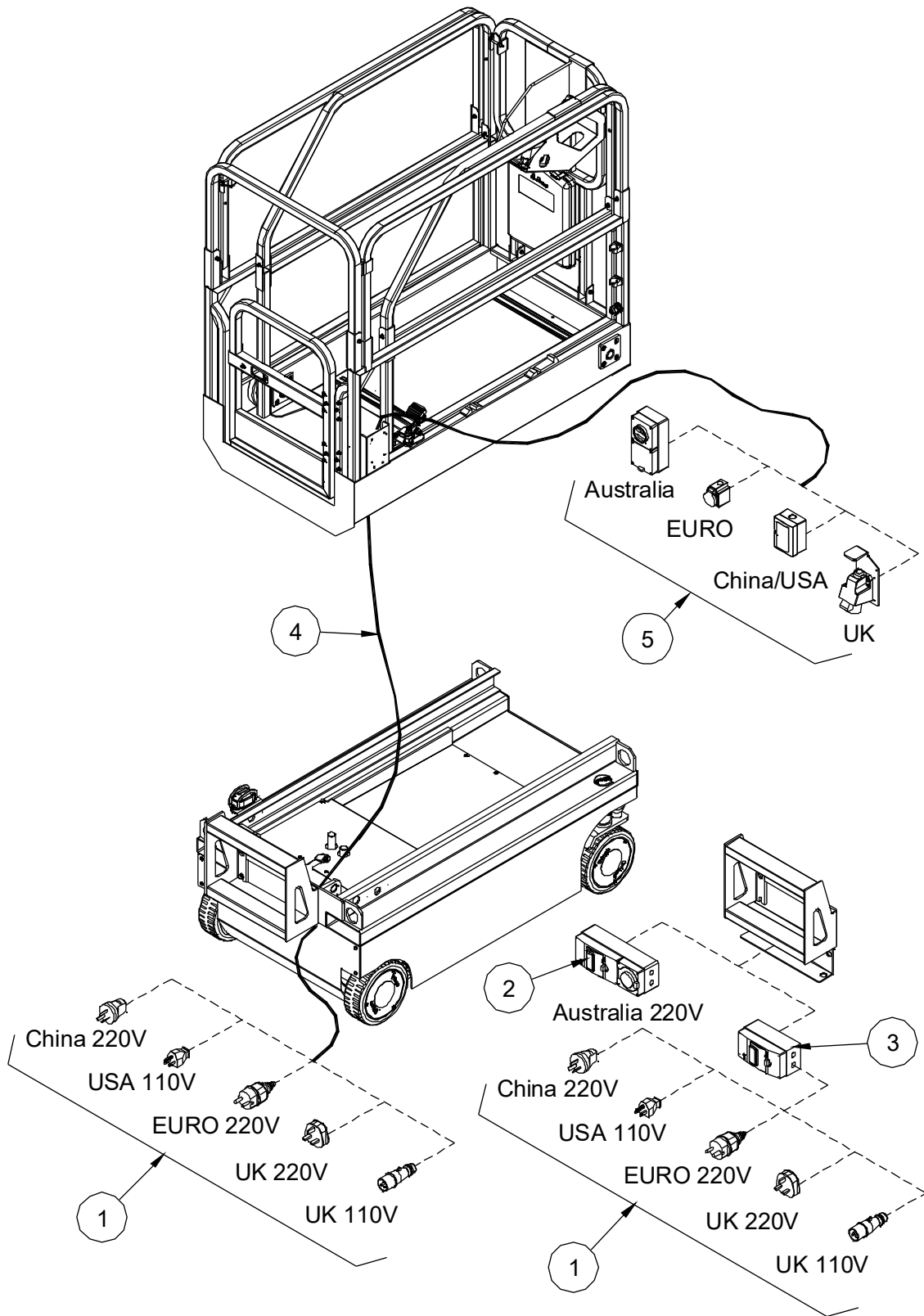

402.1 Power to Platform

Item	Part No.	Description	Qty.
1	00003148	AC plug (China 220V)	1
	00003149	AC plug (USA 110V)	1
	00003151	AC plug (European 220V)	1
	00003150	AC plug (UK 220V)	1
	00002615	AC plug (UK 110V)	1
2	00002603	AC plug (Australia 220V)	1
3	00002634	Circuit breaker (Option)	1
4	00003170	Wire cable, platform AC power	1
5	00002617	AC socket (Australia)	1
	00002709	AC socket (European)	1
	00000668	AC socket (China/USA)	1
	00004771	AC socket (UK) (AC socket bracket: 10016048)	1

Section 5 Decal

501.1 Decals with Words (CE)

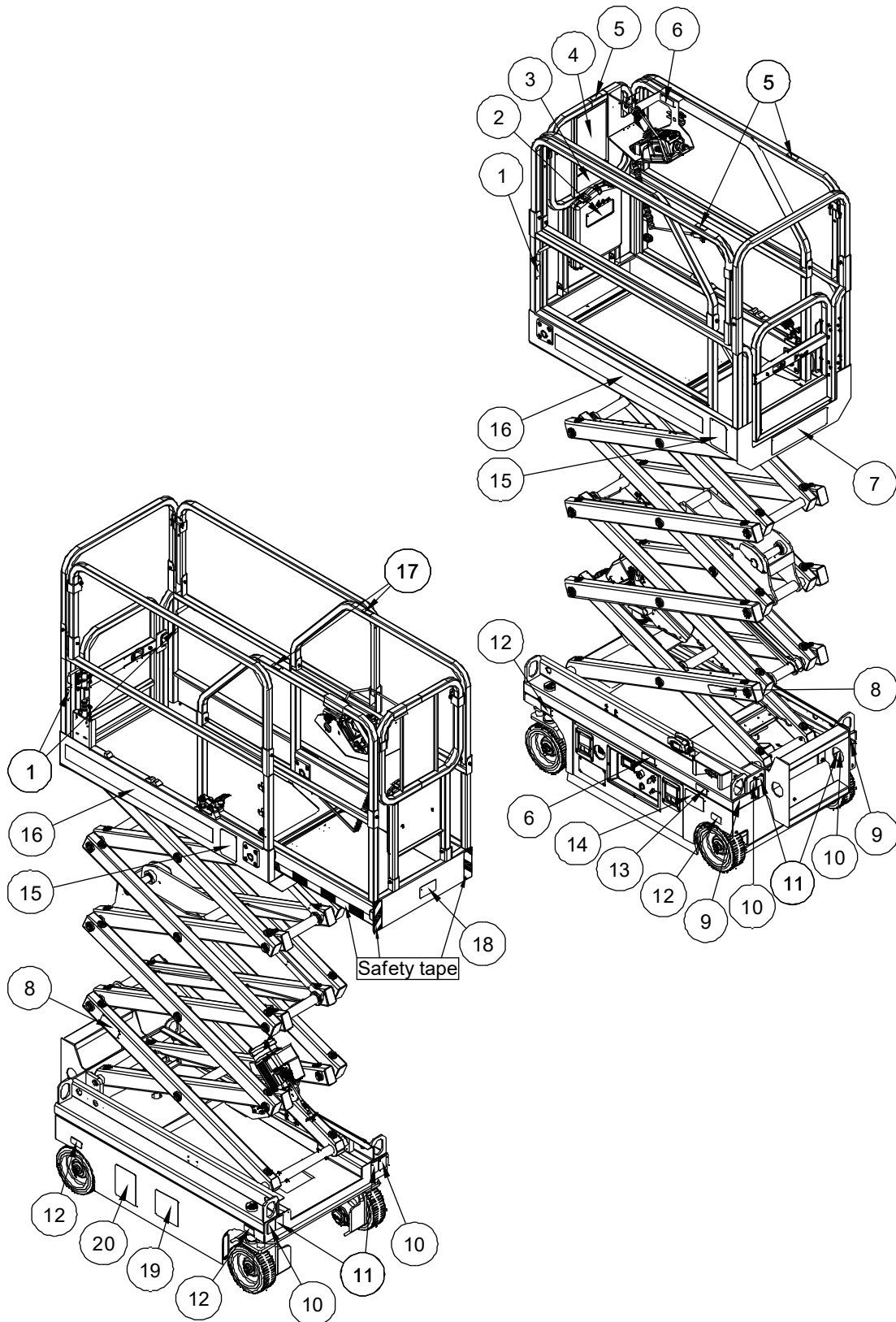

501.1 Decals with Words (CE)

Item	Part No.	Description	Qty.
1	09440011	Decal, Label-Lanyard anchorage point	3
2	09340001	Decal, Notice-Keep the manual with the machine	1
3	09440003	Decal, Danger-Tip-over hazard, tilt-alarm	1
4	09440001	Decal, Danger-General safety rules	1
5	09340070	Decal, Symbols-Non operating hand position	3
6	09340003	Decal, Instructions-Refer the operator to the instructions for use	2
7	09440039	Decal, Label-Capacity 240kg	1
8	09430044	Decal, Danger-Safety arm	2
9	09310001	Decal, Instructions-Forklift pockets	2
10	09310003	Decal, Instructions-Tie down point	4
11	09310002	Decal, Instructions-Lift point	4
12	09310028	Decal, Instructions-Maximum wheel load 450kg	4
13	09310004	Decal, Instructions-Emergency lower	1
14	09410232	Decal, Symbols-Slope rating	1
15	09440009	Decal, Caution-Max. manual force 400N (Indoor) 200N (Outdoor)	2
16	09640218	Decal, Cosmetic-JCPT0607PA	2
17	09440212	Decal, Warning-Crushing hazard	2
18	09540001	Decal, Label-CE	1
19	09410001	Decal, Danger-Explosion/burn hazard	1
20	09410003	Decal, Warning-Inspected and operation properly	1

501.1 Decals with Words (CE)

① 09440011

② 09340001

④ 09440001

③ 09440003

⑤ 09340070

⑥ 09340003

⑨ 09310001

⑩ 09310003

⑪ 09310002

⑦ 09440039

⑧ 09430044

⑫ 09310028

⑬ 09310004

⑰ 09440212

⑱ 09540001

⑭ 09410232

⑮ 09440009

⑳ 09410003

⑲ 09410001

⑰ 09640218

501.2 Decals with Words (ANSI)

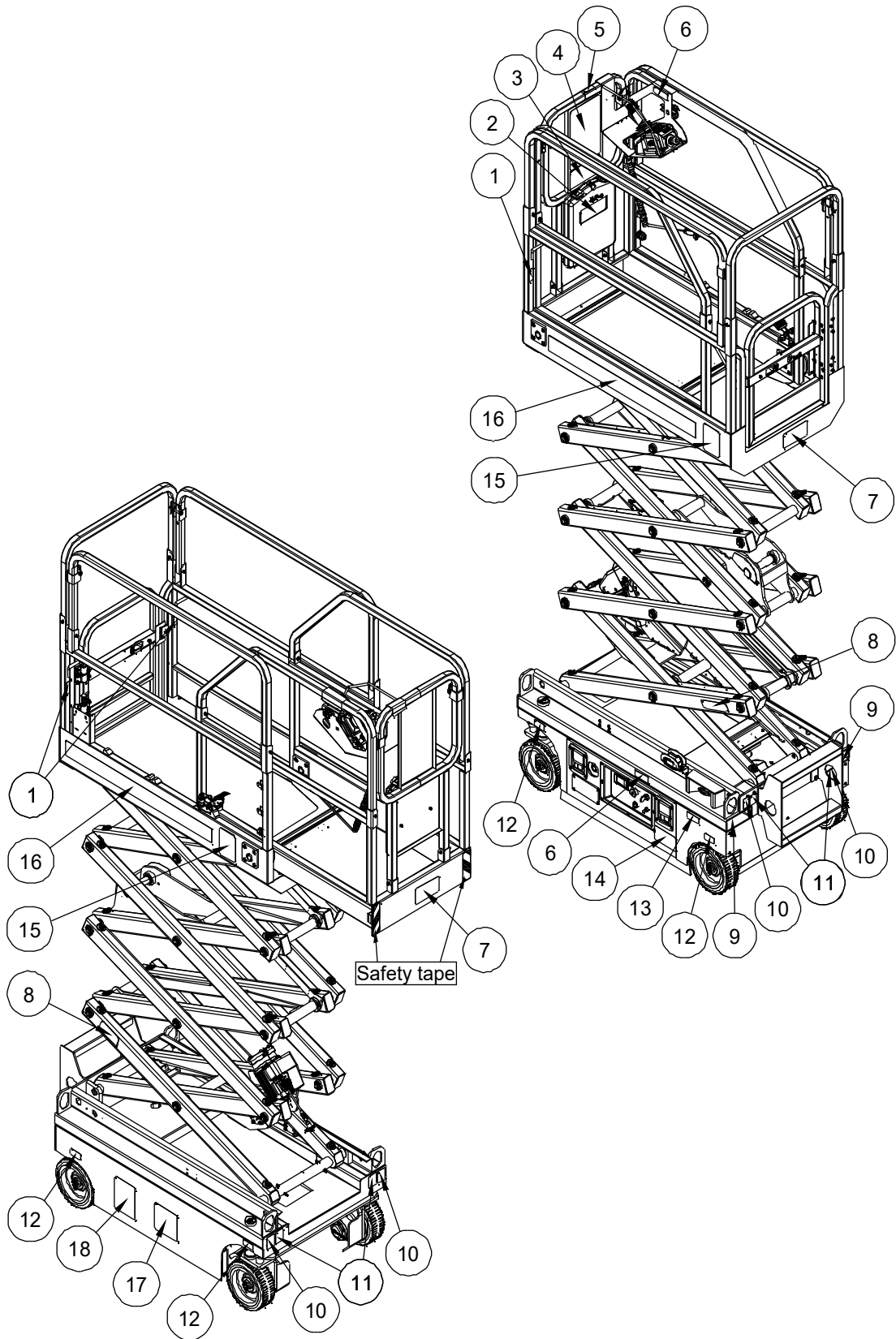

501.2 Decals with Words (ANSI)

Item	Part No.	Description	Qty.
1	09440011	Decal, Label-Lanyard anchorage point	3
2	09340001	Decal, Notice-Keep the manual with the machine	1
3	09440003	Decal, Danger-Tip-over hazard, tilt-alarm	1
4	09440037	Decal, Danger-General safety rules	1
5	09340005	Decal, Instructions-Platform controller normal position	1
6	09340003	Decal, Instructions-Refer the operator to the instructions for use	2
7	09440345	Decal, Label-Capacity 530 lbs 240kg	2
8	09430044	Decal, Danger-Safety arm	2
9	09310001	Decal, Instructions-Forklift pockets	2
10	09310003	Decal, Instructions-Tie down point	4
11	09310002	Decal, Instructions-Lift point	4
12	09310028	Decal, Instructions-Maximum wheel load 450kg	4
13	09310004	Decal, Instructions-Emergency lower	1
14	09410015	Decal, Warning-Change battery	1
15	09440302	Decal, Warning-Max. manual force 90 lbs 400N (Indoor) 45 lbs 200N (Outdoor)	2
16	09640218	Decal, Cosmetic-JCPT0607PA	2
17	09410001	Decal, Danger-Explosion/burn hazard	1
18	09410003	Decal, Warning-Inspected and operation properly	1

501.2 Decals with Words (ANSI)

① 09440011

② 09340001

④ 09440037

③ 09440003

⑤ 09340005

⑥ 09340003

⑨ 09310001

⑩ 09310003

⑪ 09310002

⑦ 09440345

⑧ 09430044

⑫ 09310028

⑬ 09310004

⑭ 09410015

⑮ 09440302

⑰ 09410001

⑱ 09410003

JCPT0607PA

502.1 Decals with Symbols (CE)

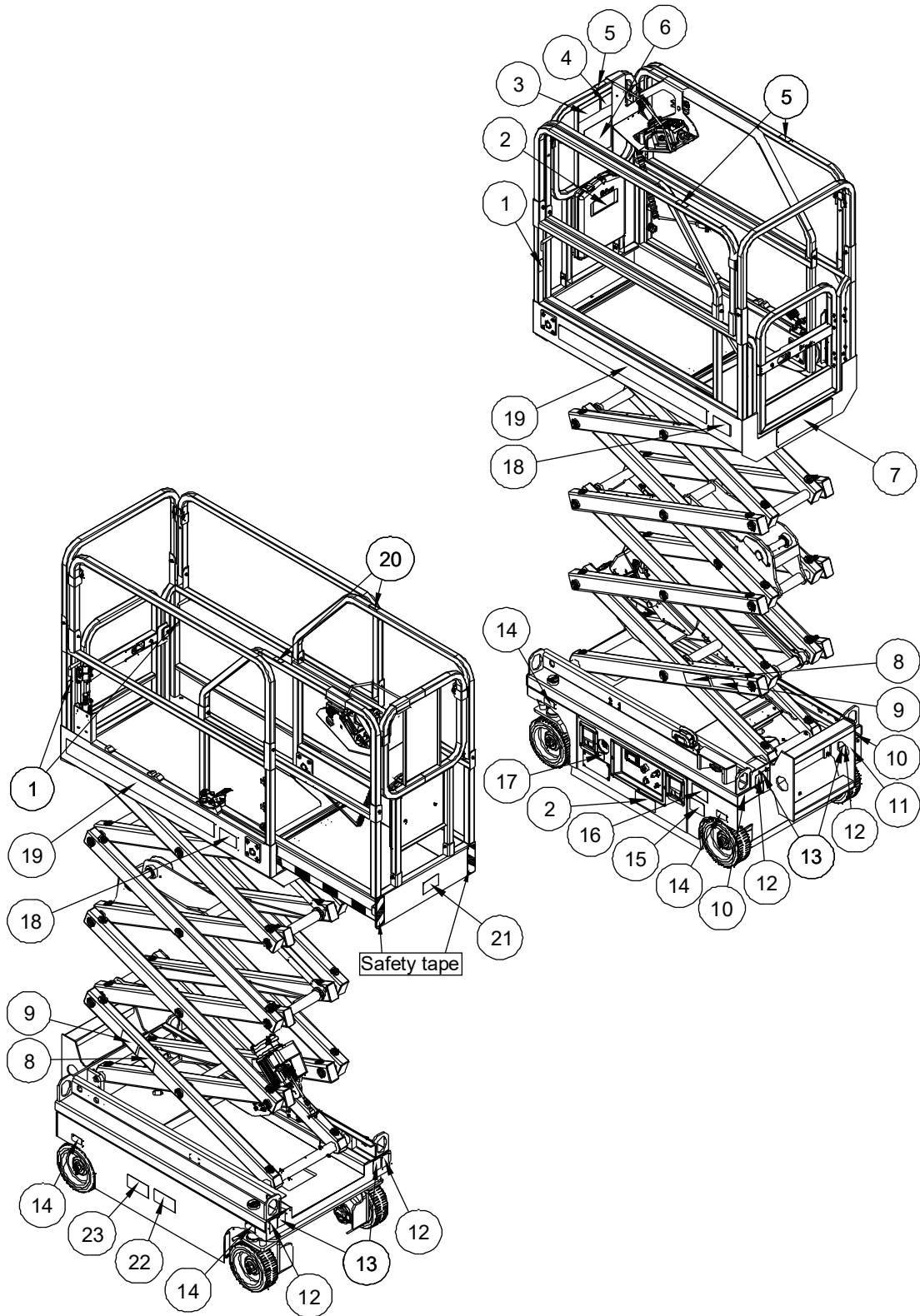

502.1 Decals with Symbols (CE)

Item	Part No.	Description	Qty.
1	09440089	Decal, Label-Lanyard anchorage point	3
2	09340026	Decal, Symbols-Refer the operator to the instructions for use	2
3	09440090	Decal, Symbols-Tip-over hazard, tilt-alarm	1
4	09340028	Decal, Instructions-Directional arrows	1
5	09340070	Decal, Symbols-Non operating hand position	3
6	09440091	Decal, Symbols-General safety rules	1
7	09440039	Decal, Label-Capacity 240kg	1
8	09430009	Decal, Symbols-Keep away from moving parts	2
9	09430008	Decal, Symbols-Safety arm	2
10	09310001	Decal, Instructions-Forklift pockets	2
11	09310226	Decal, Symbols-Platform power instructions	1
12	09310003	Decal, Instructions-Tie down point	4
13	09310002	Decal, Instructions-Lift point	4
14	09310028	Decal, Instructions-Maximum wheel load 450kg	4
15	09410232	Decal, Symbols-Slope rating	1
16	09310096	Decal, Symbols-Emergency lower	1
17	09310100	Decal, Symbols-Battery charging instructions	1
18	09440085	Decal, Symbols-Max. manual force 400N (Indoor) 200N (Outdoor)	2
19	09640218	Decal, Cosmetic-JCPT0607PA	2
20	09440212	Decal, Warning-Crushing hazard	2
21	09540001	Decal, Label-CE	1
22	09410048	Decal, Symbols-Explosion/burn hazard	1
23	09410049	Decal, Symbols-Electrocution hazard	1

502.1 Decals with Symbols (CE)

<p>① 09440089</p> <p>P.N. 37422</p>	<p>② 09340026</p> <p>P.N. 37421</p>	<p>③ 09440090</p> <p>P.N. 37414</p>	<p>④ 09340028</p> <p>P.N. 44343</p>
<p>⑤ 09340070</p> <p>P.N. 37425</p>	<p>⑥ 09440091</p> <p>P.N. 37424</p>	<p>⑧ 09430009</p> <p>P.N. 37421</p>	<p>⑩ 09310001</p> <p>09310001</p>
<p>⑦ 09440039</p> <p>09440039</p>	<p>⑨ 09430008</p> <p>P.N. 37430</p>	<p>⑪ 09310226</p> <p>230 Volt</p>	<p>⑫ 09310003</p> <p>09310003</p>
<p>⑭ 09310028</p> <p>09310028 B</p>	<p>⑮ 09310096</p> <p>P.N. 37427</p>	<p>⑰ 09440085</p> <p>P.N. 37487</p>	<p>⑳ 09540001</p> <p>09540001</p>
<p>⑯ 09440212</p> <p>09440212</p>	<p>㉑ 09410232</p> <p>P.N. 34380</p>	<p>㉒ 09410048</p> <p>P.N. 37429</p>	<p>㉓ 09410049</p> <p>P.N. 37432</p>
<p>⑱ 09640218</p> <p>JCPT0607PA</p>	<p>⑳ 09540001</p> <p>P.N. 34380</p>	<p>㉑ 09410232</p> <p>P.N. 34380</p>	<p>㉒ 09410048</p> <p>P.N. 37429</p>
<p>㉑ 09410232</p> <p>P.N. 34380</p>	<p>㉒ 09410048</p> <p>P.N. 37429</p>	<p>㉓ 09410049</p> <p>P.N. 37432</p>	<p>㉔ 09310002</p> <p>09310002</p>

502.2 Decals with Symbols (ANSI)

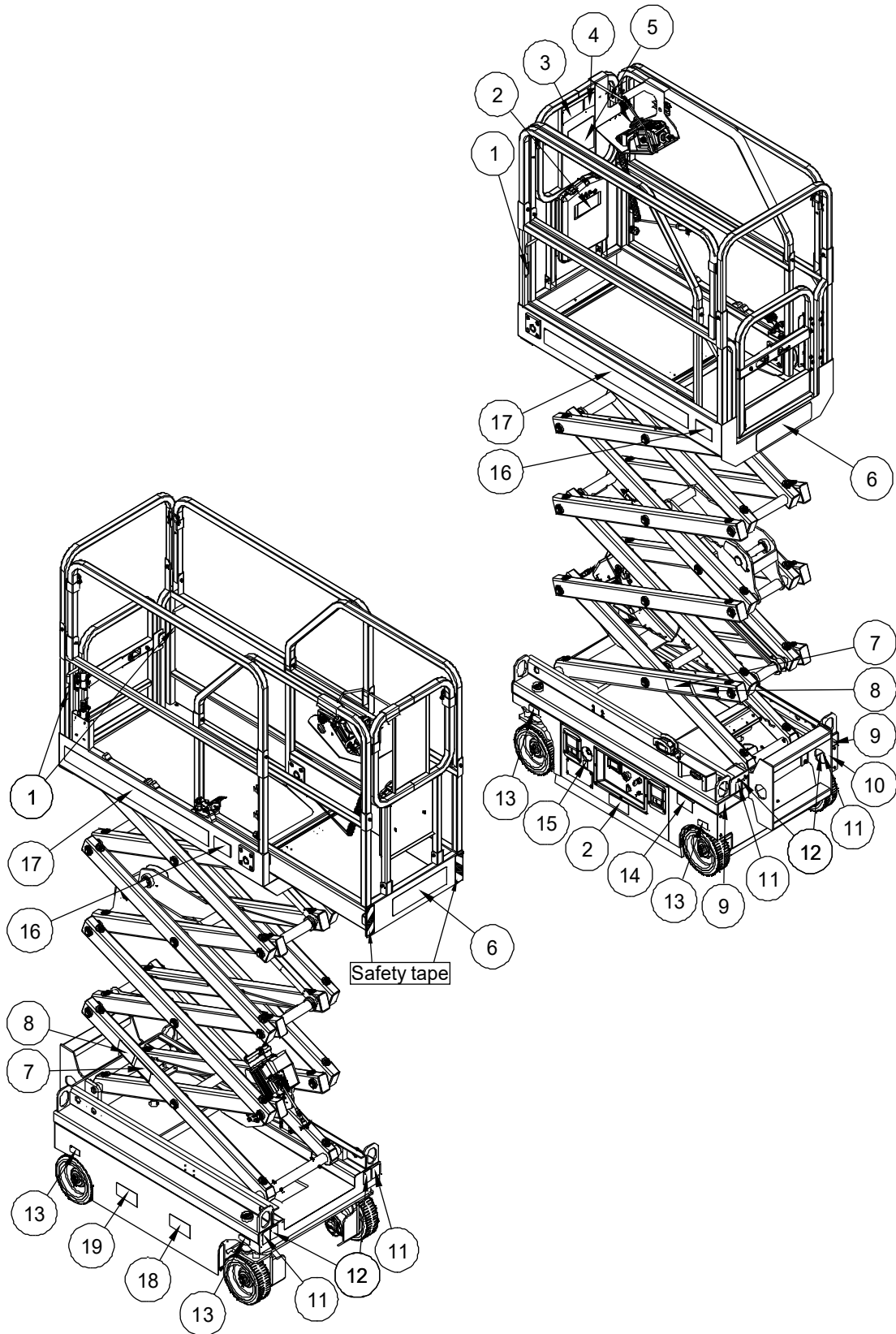

502.2 Decals with Symbols (ANSI)

Item	Part No.	Description	Qty.
1	09440089	Decal, Label-Lanyard anchorage point	3
2	09340026	Decal, Symbols-Refer the operator to the instructions for use	2
3	09440090	Decal, Symbols-Tip-over hazard, tilt-alarm	1
4	09340028	Decal, Instructions-Directional arrows	1
5	09440091	Decal, Symbols-General safety rules	1
6	09440345	Decal, Label-Capacity 530 lbs 240kg	2
7	09430009	Decal, Symbols-Keep away from moving parts	2
8	09430008	Decal, Symbols-Safety arm	2
9	09310001	Decal, Instructions-Forklift pockets	2
10	09310554	Decal, Symbols-Platform power instructions	1
11	09310003	Decal, Instructions-Tie down point	4
12	09310002	Decal, Instructions-Lift point	4
13	09310028	Decal, Instructions-Maximum wheel load 450kg	4
14	09310096	Decal, Symbols-Emergency lower	1
15	09310528	Decal, Symbols-Battery charging instructions	1
16	09440085	Decal, Symbols-Max. manual force 400N (Indoor) 200N (Outdoor)	2
17	09640218	Decal, Cosmetic-JCPT0607PA	2
18	09410048	Decal, Symbols-Explosion/burn hazard	1
19	09410049	Decal, Symbols-Electrocution hazard	1

502.2 Decals with Symbols (ANSI)

<p>① 09440089</p> 	<p>② 09340026</p> 	<p>⑤ 09440091</p> 		
<p>③ 09440090</p> 	<p>④ 09340028</p> 			
<p>⑥ 09440345</p> 	<p>⑨ 09310001</p> 			
<p>⑦ 09430009</p> 	<p>⑧ 09430008</p> 	<p>⑩ 09310554</p> 		
<p>⑪ 09310003</p> 	<p>⑫ 09310002</p> 	<p>⑬ 09310028</p> 	<p>⑭ 09310096</p> 	<p>⑮ 09310528</p> 
<p>⑰ 09440085</p> 	<p>⑱ 09410048</p> 	<p>⑲ 09410049</p> 		
<p>⑳ 09640218</p> <h1>JCPT0607PA</h1>				

DINGLI AWP INDIA PRIVATE LIMITED

Address: Sahney Towers, 81, First Floor, Poonamallee High Road, Nerkundram,

Chennai, Tamil Nadu - 600 107

Telephone: +91-98846 48464

E-mail: support@dinglisaarc.com

Website: www.dinglisaarc.com

DINGLI