

SPECIFICATIONS

Size	Metric	British
Max. Working Height A	11.00m	36ft 1in
Max. Platform Height B	9.00m	29ft 6in
Overall Length(Stowed) C	1.70m	5ft 7in
Overall Width(Stowed) D	0.82m	2ft 8in
Overall Height(Stowed) E	1.99m	6ft 6in
Outrigger Footprint(Length F ×Width G)	2.31m/2.39m	7ft 7in/7ft 10in
Platform Size(Length H ×Width I)	1.40m×0.65m	4ft 7in×2ft 2in
Ground Clearance	0.055m	2in
BackSize	0.18m	7in
FrontSize	0.18m	7in

Performance		
S.W.L	300kg	661lb
Max. Occupants	2	2
Up/Down Speed	62/40sec	62/40sec

Weight		
Weight - AC	780kg	1719lb
Weight - DC	840kg	1851lb

Power		
Battery	2×12V/85Ah	2×12V/85Ah
Charger	12V/15A	12V/15A
Lifting Motor - AC	220VAC/1.5kW	220VAC/1.5kW
Lifting Motor - DC	12VDC/2.5kW	12VDC/2.5kW



ELECTRIC

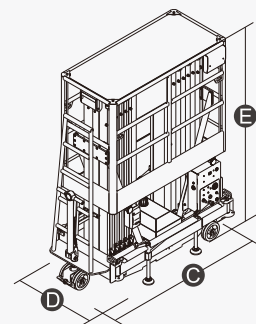
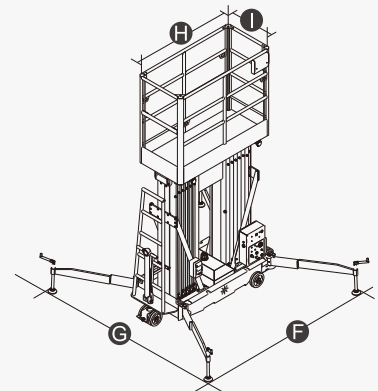
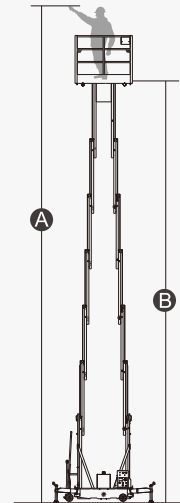

FEATURES

Standard Items

- Self-Locking Gates
- Emergency Descent System
- Tubing Explosion-Proof System
- Motion Alarm
- Charging Indicator(DC type)
- Charging Protection System(DC type)
- Flashing Beacon
- Lanyard Attachment Point
- Tie-Down And Lifting Points
- Emergency Stop Button



DINGLI AWP INDIA PRIVATE LIMITED

Address: Sahney Towers, 81, First Floor, Poonamallee High Road, Nerkundram,

Chennai, Tamil Nadu - 600 107

Telephone: +91-98846 48464

E-mail: support@dinglisaarc.com

Website: <https://dinglisaarc.com>

