

SPECIFICATIONS

Size	Metric	British
Max. Working Height A	11.00m	36ft 1in
Max. Platform Height B	9.00m	29ft 6in
Overall Length C	1.34m	4ft 5in
Overall Width D	0.75m	2ft 6in
Overall Height E	1.99m	6ft 6in
Outrigger Footprint(Length F /Width G)	1.70m/1.86m	5ft 7in/6ft 1in
Platform Size(Length×Width)	0.70m×0.60m	2ft 4in×2ft
Ground Clearance	0.055m	2in
Tyres(Front)	0.20m	8in
Tyres(Back)	0.13m	5in

Performance		
S.W.L	150kg	330lb
Max. Occupants	1	1
Up/Down Speed	34/22sec	34/22sec

Weight		
Weight - AC	450kg	992lb
Weight - DC	470kg	1036lb

Power		
Battery	12V/85Ah	12V/85Ah
Charger	12V/15A	12V/15A
Lifting Motor - AC	220VAC/1.5kW	220VAC/1.5kW
Lifting Motor - DC	12VDC/1.5kW	12VDC/1.5kW

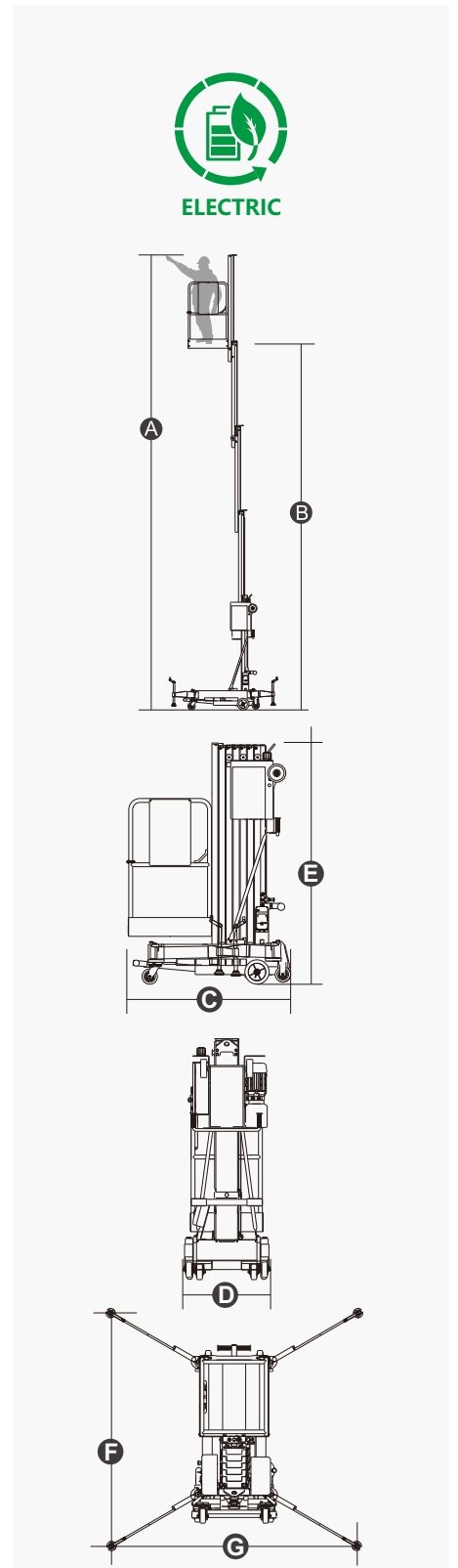

FEATURES

Standard Items

- Self-Locking Gates
- Emergency Descent System
- Tubing Explosion-Proof System
- Motion Alarm
- Charging Indicator(DC type)
- Charging Protection System(DC type)
- Flashing Beacon
- Lanyard Attachment Point
- Tie-Down And Lifting Points
- Emergency Stop Button



DINGLI AWP INDIA PRIVATE LIMITED

Address: Sahney Towers, 81, First Floor, Poonamallee High Road, Nerkundram,

Chennai, Tamil Nadu - 600 107

Telephone: +91-98846 48464

E-mail: support@dinglisaarc.com

Website: <https://dinglisaarc.com>



Due to continuous technology updates, technical parameters are subject to change without notice. This picture book is for reference only, the actual product shall prevail. The copyright is owned by zhejiang dingli, any content may not be copied for any purpose without written permission.

2022-10