

SPECIFICATIONS

Size	Metric	British
Max. Working Height	16.27m	53ft 4in
Max. Platform Height	14.27m	46ft 10in
Max. Operating Range(+0.6m)	8.69m	28ft 6in
Max. Platform Range	8.09m	26ft 6in
Flatbed Transport Dimensions (L×W×H)	5.17m×2.44m×2.58m	16ft11in×8ft×8ft 5in
Standard Container Transport	All Applicable	All Applicable
Platform Size(Length×Width)	1.83m×0.79m	6ft×2ft 7in
Turntable Tailswing	0	0
Ground Clearance A	0.31m	1ft
Wheelbase B	2.40m	7ft 10in
Turning Radius(Inside/Outside)	3m/4.73m	9ft 10in/15ft 6in
Tyres	315/55 D20	315/55 D20
Max. Up And Over Clearance	7.30m	23ft 11in
Max. Down Probing Depth	0.42m	1ft 4in

Performance		
S.W.L	320kg	705lb
Max. Occupants	2	2
Gradeability	40%	40%
Travel Speed(Stowed)	6.0km/h	3.7mph
Travel Speed(Raised)	1.1km/h	0.7mph
Max. Working Slope	X-5°/Y-5°	X-5°/Y-5°
Turret Rotation	360°Continuous	360°Continuous
Platform Rotation	180°	180°
Jib Movement	132°	132°

Weight		
Overall Weight	8300kg	18298lb

Power		
Diesel Engine	Kubota Z482/9.8kW	Kubota Z482/9.8kW
Battery	48V/300Ah	48V/300Ah
Charger	48VDC/60A	48VDC/60A
Driving Motor	34AC/9kW	34AC/9kW
Lifting Motor	34VAC/13kW	34VAC/13kW
Diesel Tank	90L	23gal
Hydraulic Tank	145L	38gal

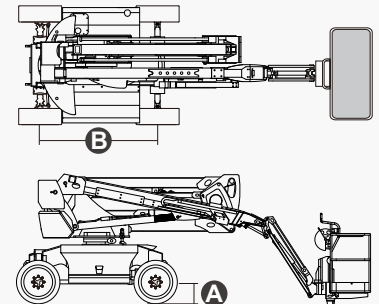
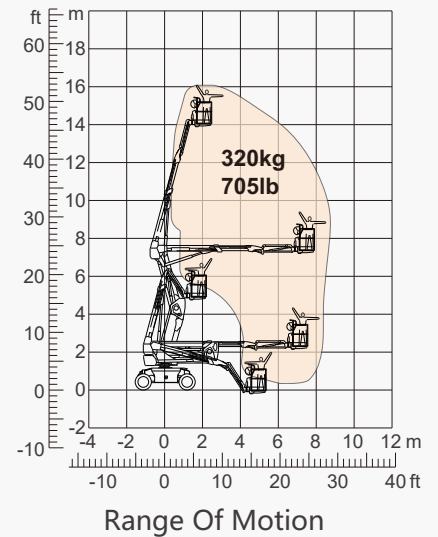
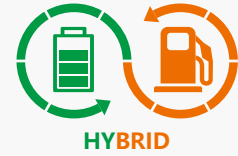

FEATURES

Standard Items

- 1.50m (4ft 11in) Jib
- Front Oscillating Axle
- Two-Wheel Steering
- Four-Wheel Drive
- Self-Leveling Platform
- 180° Left And Right Swing Platform
- Proportional Joystick Controls
- Thumb Rocker Steer
- Drive Enable
- Ac Power Cord To Platform
- Tilt Alarm
- Descent Alarm
- Flash
- Horn
- Hour Meter
- Integral Integrated Special Drive Axle For Construction Machinery
- 360° Continuous Turntable Rotation
- Positive Traction Four Wheel Drive
- Platform Load Sense System
- Fault Diagnosis System
- Operator Anti-crushing Protection System
- Harsh Environment Kits
- 12V DC Auxiliary Power
- Battery 300Ah/48V
- Driving Motor 9kW 4834rpm
- Lifting Motor 13kW 1855rpm



Articulated
Boom-BA



Working
Height-16m



Jib



Hybrid-H



Rough
Terrain-RT

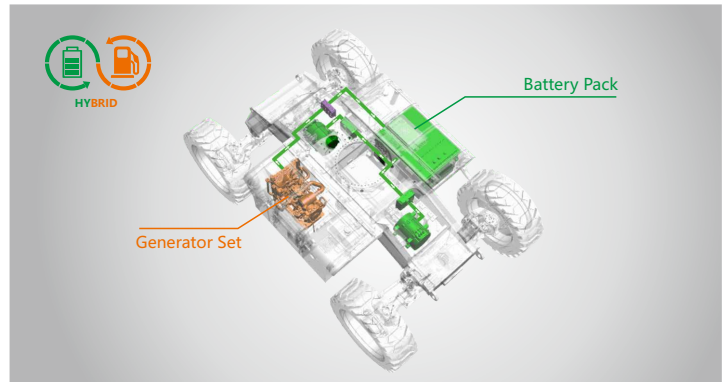

Hybrid-Super Long Endurance Of 30 Days

DINGLI AWP INDIA PRIVATE LIMITED

Address: Sahney Towers, 81, First Floor, Poonamallee High Road, Nerkundram,
Chennai, Tamil Nadu - 600 107
Telephone: +91-98846 48464
E-mail: support@dinglisaarc.com
Website: <https://dinglisaarc.com>

